

MOTORS M

HYDRAULIC MOTORS

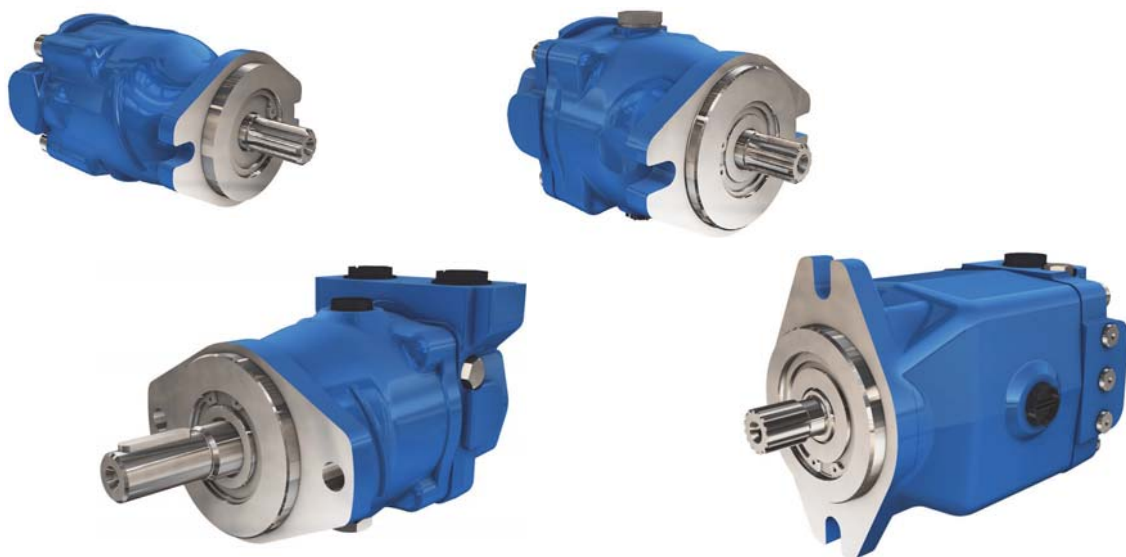

T E C H N I C A L C A T A L O G

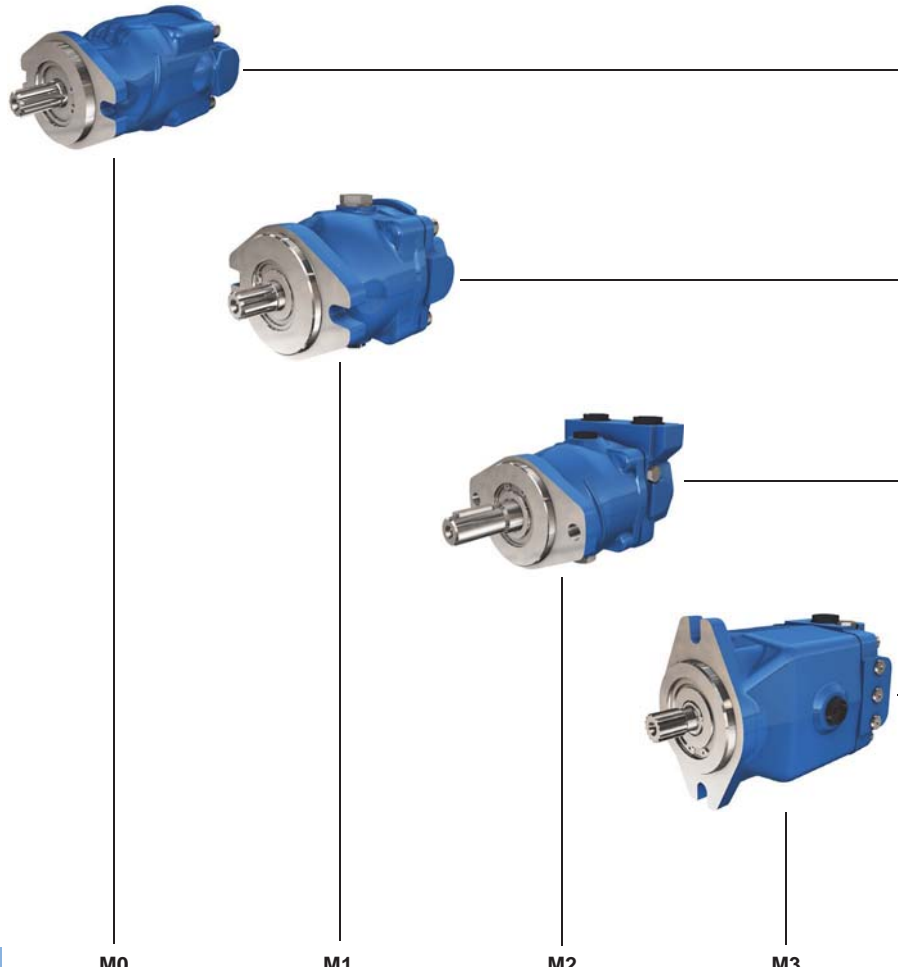

| | | M0 | M1 | M2 | M3 |
|--|---|-------------------------------------|-------------------------------------|--------------------------------------|--------------------------------------|
| Displacement | cm ³ /rev [in ³ /rev.] | From 7,07 [0.43] to 17,84 [1.09] | From 9,08 [0.55] to 20,31 [1.24] | From 21,05 [1.28] to 49,06 [2.99] | From 49,57 [3.02] to 64,60 [3.94] |
| Max. speed | rpm | 3 600 | | | |
| Min. speed | rpm | 500 | | | |
| Rated pressure | bar [PSI] | 210 [3045] | | | 250 [3625] |
| Max. pressure | bar [PSI] | 300 [4351] | 320 [4641] | 315 [4569] | 350 [5076] |
| Min. charge pressure | bar [PSI] | 5-6 [72-87] | | | |
| Case pressure continuous | bar [PSI] | 1,5 [21.76] | | | |
| Case pressure max. (cold start) | bar [PSI] | 2,5 [36.26] | | | |
| Mounting flange and shaft | | SAE-A & SAE-B | | | |
| Weight | kg [lb] | 3.5 [7.72] | 8 [17.64] | 12 [26.46] | 15 [33.07] |
| Rotation | | Clockwise or Counterclockwise | | | |



CONTENT

| | | | | |
|--|-----------------------------|-----------|---|----------------------|
| | MOTOR M0 | 5 | → | Motor M0 |
| | Model Code | 5 | | |
| | Characteristics | 6 | | |
| | Options | 9 | | |
| | | | | |
| | MOTOR M1 | 11 | → | Motor M1 |
| | Model Code | 11 | | |
| | Characteristics | 12 | | |
| | Options | 17 | | |
| | | | | |
| | MOTOR M2 | 23 | → | Motor M2 |
| | Model Code | 23 | | |
| | Characteristics | 24 | | |
| | Options | 29 | | |
| | | | | |
| | MOTOR M3 | 35 | → | Motor M3 |
| | Model Code | 35 | | |
| | Characteristics | 36 | | |
| | Options | 40 | | |
| | | | | |
| | OPERATING PARAMETERS | 46 | → | Operating parameters |



Methodology :

This document is intended for manufacturers of machines that incorporate Poclain Hydraulics products. It describes the technical characteristics of Poclain Hydraulics products and specifies installation conditions that will ensure optimum operation. This document includes important comments concerning safety. They are indicated in the following way:



Safety comment.

This document also includes essential operating instructions for the product and general information. These are indicated in the following way:



Essential instructions.



General information .



Information on the model number. Information on the model code.



Weight of component without oil.



Volume of oil.



Units.



Tightening torque.



Screws.



Information intended for Poclain-Hydraulics personnel.

The views in this document are created using metric standards.

The dimensional data is given in mm and in inches (inches are between brackets and italic)





MOTOR M0

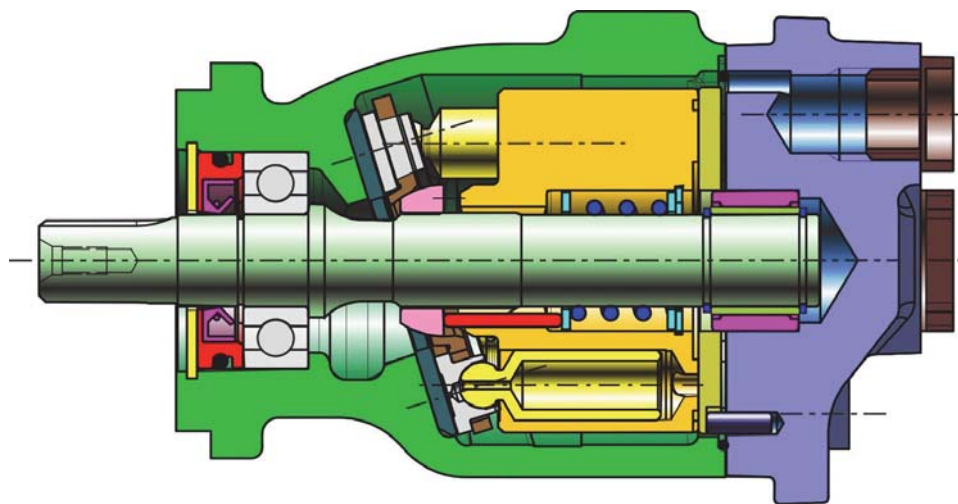

Motor M0

Motor M1

Motor M2

Motor M3

Operating parameters

MODEL CODE



1

| Displacement cm ³ /rev [in ³ /rev] | |
|--|----|
| 7,07 [0.43] | 07 |
| 9,07 [0.55] | 09 |
| 11,82 [0.72] | 11 |
| 13,07 [0.80] | 13 |
| 13,69 [0.84] | 14 |
| 16,78 [1.02] | 17 |
| 17,84 [1.09] | 18 |

2

| Shaft | |
|---------------------------------|----|
| Key shaft (D=15,875 [0.625]) | C1 |
| Splined shaft (z=9; 16/32 D.P.) | S1 |

3

| Connections | |
|-------------|----|
| Side | 02 |
| Rear | 04 |

4

| Options | |
|---------------------------------|----|
| Without options | 00 |
| Roller bearings | CR |
| Customized identification plate | DP |
| Fluorinated elastomer seals | EV |
| UNF Thread ports | FU |
| Finishing coat | PA |

 In case of request for a combination of several options, please contact your Poclain Hydraulics application engineer for further information.



CHARACTERISTICS

Features

| | | |
|----------------------------------|--|---|
| Displacement | cm ³ /rev [in ³ /rev.] | From 7,07 [0.43] to 17,84 [1.09] |
| Max. speed | rpm | 3 600 |
| Min. speed | rpm | 500 |
| Rated pressure | bar [PSI] | 210 [3046] |
| Max. pressure | bar [PSI] | 300 [4351] |
| Min. charge pressure | bar [PSI] | 5-6 [72-87] |
| Mounting flange and shaft | | Key shaft or splined shaft |
| Weight | kg [lb] | 3,5 [7.72] |
| Rotation | | Clockwise (B to A) or Counterclockwise (A to B) |

Motor Performance

Power of the motor given at rated pressure and max. speed

| | | | | | | | |
|--|-------------|--------------|--------------|--------------|--------------|--------------|--------------|
| Displacement cm ³ /rev [in ³ /rev] | 7,07 [0.43] | 9,07 [0.55] | 11,82 [0.72] | 13,07 [0.80] | 13,69 [0.84] | 16,78 [1.02] | 17,84 [1.09] |
| Power kW [hp] | 8,9 [11.94] | 11,4 [15.29] | 14,9 [19.98] | 16,5 [22.13] | 17,2 [23.07] | 21,1 [28.30] | 22,5 [30.17] |

Dimensions

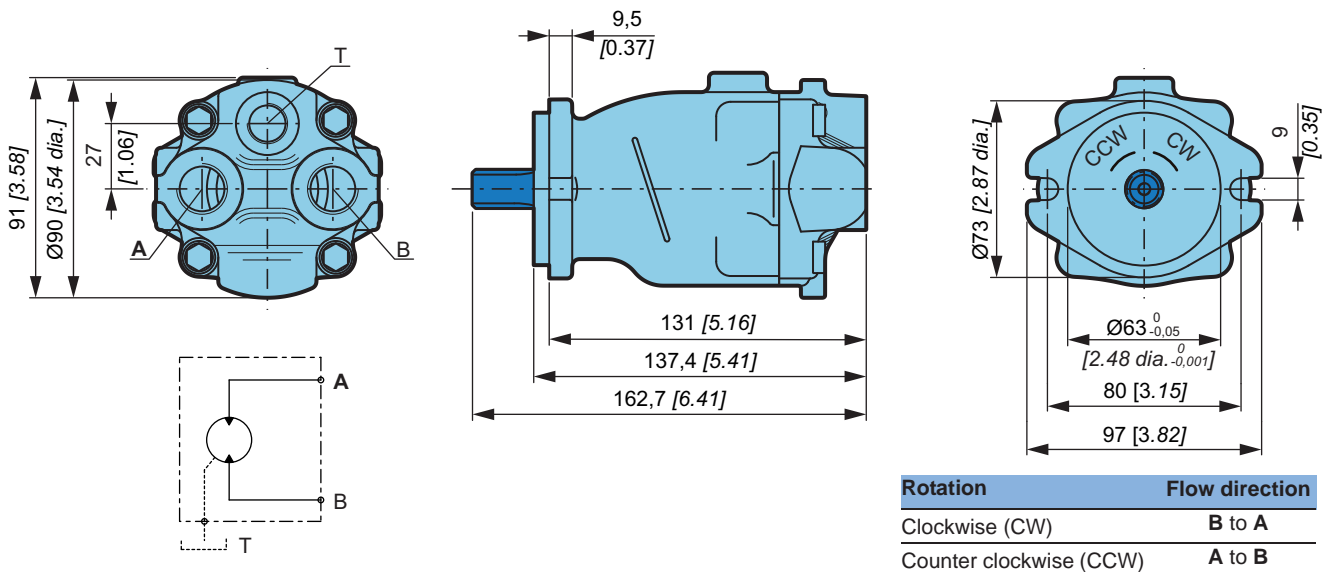



Mounting flanges and shaft



Motor M0

C1 Key shaft

Max. torque: 65 Nm [575 in.lbf]

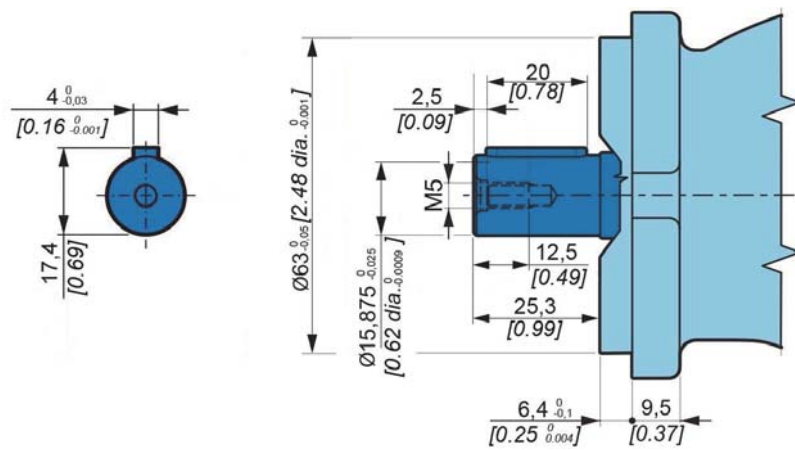

Motor M1

S1 Splined shaft

Max. torque: 80 Nm [708 in.lbf]

| Splined info | |
|-----------------|------------------|
| Standard | ANSI B92.1a-1996 |
| Pitch | 16/32" D.P. |
| Number of teeth | 9 |
| Pressure angle | 30° |
| Tolerance class | 5 |

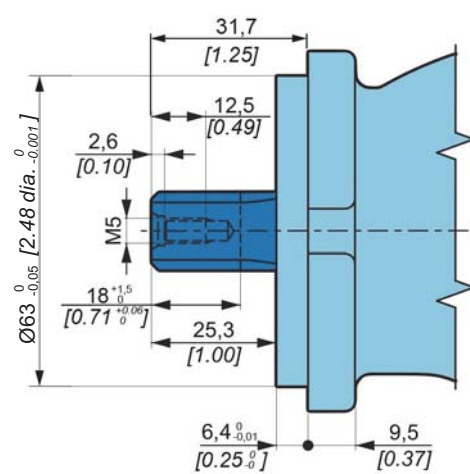

Motor M2

Motor M3

Operating parameters



Connections



02 Side connection

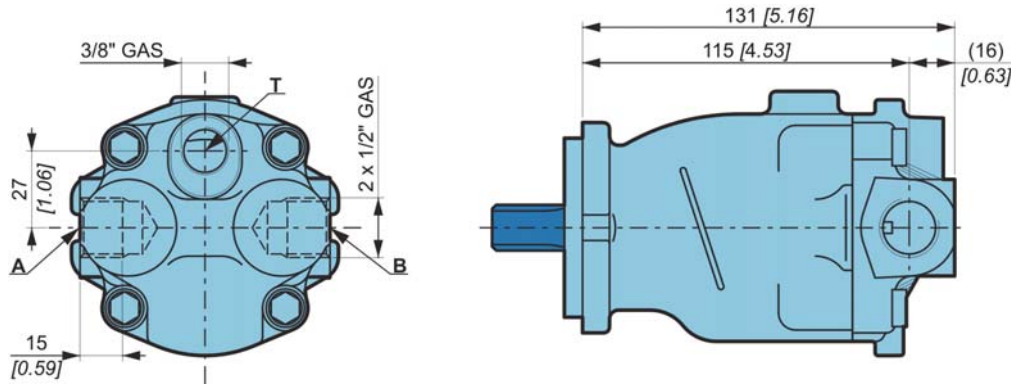

04 Rear connection

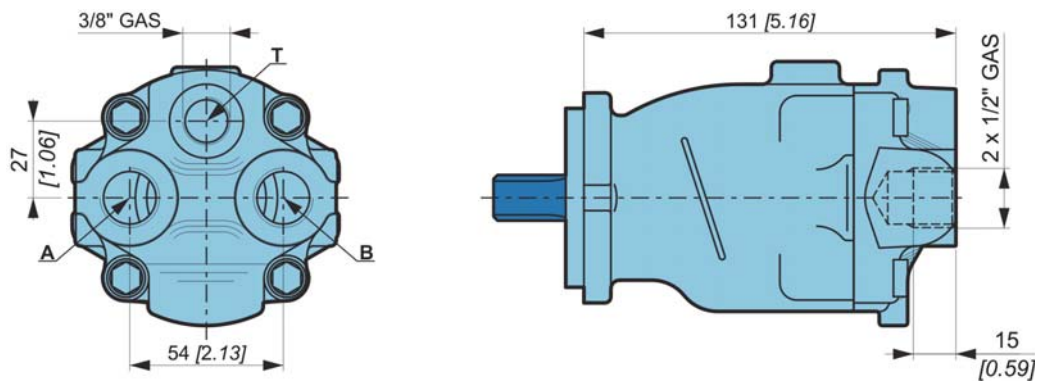



OPTIONS

Roller Bearing



It is an optional high capacity bearing.

Depending on the characteristics of shaft load, the duty cycle of the application and the expected life time of your application, Roller bearing might be needed.

Consult your Poclairn Hydraulics Application Engineer.

Customized identification plate



It is possible to provide our products with dedicated plate (your part number engraved on the plate) when requested.



This option is available only for minimum volume of 50 pieces.



Consult your Poclairn Hydraulics application engineer for other possibilities.

Fluorinated elastomer seals



Standard NBR sealing are designed to resist temperatures up to 90°C [194° F] and HV type oils.

If your application is outside these limits, fluorinated elastomer seals might be recommended.

Consult your Poclairn Hydraulics Application Engineer.

UNF Thread ports



The power supply ports A, B and drain port T are also available with UNF threads.

| Port | Function | ISO 11926-1 (option FU) |
|------|--------------|----------------------------|
| A; B | Power supply | 3/4-16 UNF-SAE |
| T | Drain | 9/16-18 UNF-SAE |

Motor M0

Motor M1

Motor M2

Motor M3

Operating parameters



Finishing coat



The motors can be delivered with finishing coat when requested. Standard paint is RAL 9005 (black color).



Consult your Poclain Hydraulics application engineer for other colors of topcoat.



MOTOR M1

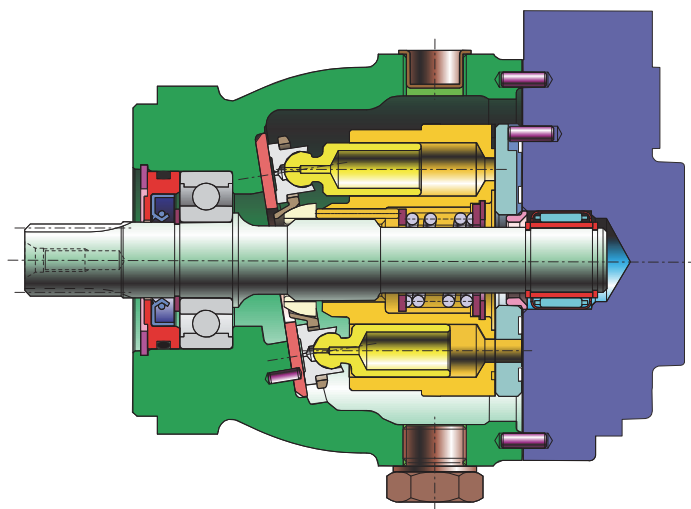

Motor M0

Motor M1

Motor M2

Motor M3

Operating parameters

MODEL CODE



1

| Displacement cm ³ /rev [in ³ /rev] | |
|--|----|
| 9,08 [0.55] | 09 |
| 10,11 [0.62] | 10 |
| 12,19 [0.74] | 12 |
| 15,35 [0.94] | 15 |
| 17,80 [1.09] | 17 |
| 19,05 [1.16] | 20 |
| 20,31 [1.24] | 21 |

2

| Shaft | |
|----------------------------------|----|
| Key shaft (D=19 mm [0.75 inch]) | C2 |
| Splined shaft (Z=11; 16/32 D.P.) | S2 |
| Splined shaft (Z=13; 16/32 D.P.) | S3 |

3

| Connections | |
|---------------|----|
| Side | 02 |
| Twin port | 03 |
| Rear | 04 |
| Side and rear | 05 |

4

| Options | |
|---------------------------------|----|
| Without options | 00 |
| Roller bearings | CR |
| Customized identification plate | DP |
| Fluorinated elastomer seals | EV |
| Flange port | FS |
| UNF Thread ports | FU |
| Relief valve on "A" | MA |
| Relief valve on "B" | MB |
| Relief valve on "A+B" | MM |
| Finishing coat | PA |
| Anticavitation valve on "A" | RA |
| Anticavitation valve on "B" | RB |
| Anticavitation valve on "A+B" | RR |
| Rear drain port | RD |
| Flushing valve | VS |



In case of request for a combination of several options, please contact your Poclain Hydraulics application engineer for further information.

5*

| High pressure relief valve setting Max. system pressure (bar [PSI]) | |
|--|----|
| 150 [2175] | 15 |
| 200 [2900] | 20 |
| 250 [3625] | 25 |
| 300 [4351] | 30 |

* Motors with option MA, MB, MM.



CHARACTERISTICS

Features

| | | |
|----------------------------------|--|---|
| Displacement | cm ³ /rev [in ³ /rev.] | From 9,08 [0.55] to 20,31 [1.24] |
| Max. speed | rpm | 3 600 |
| Min. speed | rpm | 500 |
| Rated pressure | bar [PSI] | 210 [3046] |
| Max. pressure | bar [PSI] | 320 [4641] |
| Min. charge pressure | bar [PSI] | 5-6 [72-87] |
| Mounting flange and shaft | | SAE-A |
| Weight | kg [lb] | 8 [17.64] |
| Rotation | | Clockwise (B to A) or Counterclockwise (A to B) |

Motor Performance

Power of the motor given at rated pressure and max. speed

| | | | | | | |
|---|--------------|--------------|--------------|--------------|--------------|--------------|
| Displacement cm ³ /rev [in ³ /rev.] | 9,08 [0.55] | 12,19 [0.74] | 15,35 [0.94] | 17,80 [1.09] | 19,05 [1.16] | 20,31 [1.24] |
| Power kW [hp] | 11,4 [15.29] | 15,4 [20.65] | 19,3 [25.88] | 22,4 [30.04] | 24,0 [32.18] | 25,6 [34.33] |

Dimensions

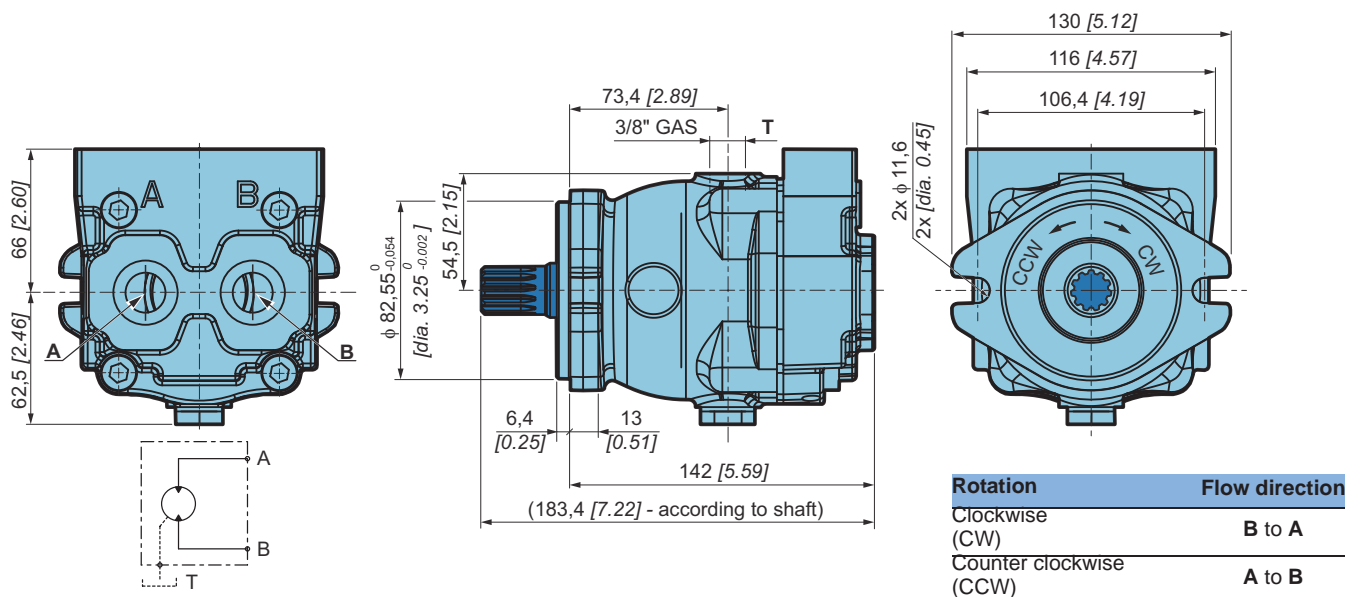



Mounting flanges and shaft



C2 Key shaft

Max. torque: 140 Nm [1239 in.lbf]

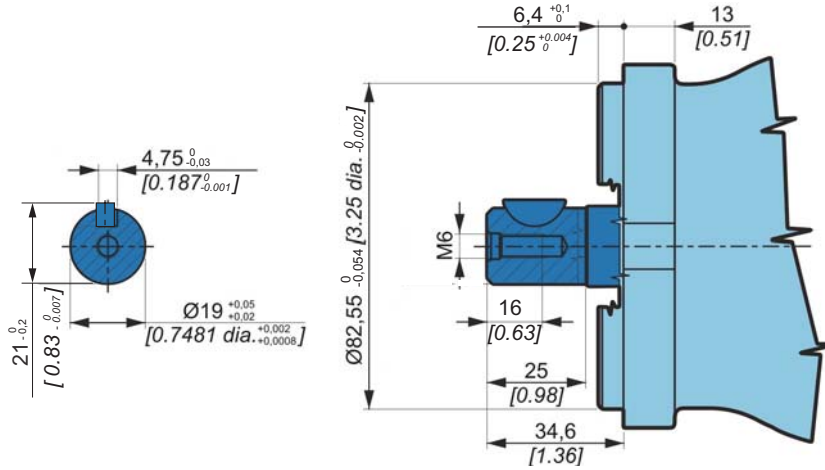

S2 Splined shaft

Max. torque: 140 Nm [1239 in.lbf]

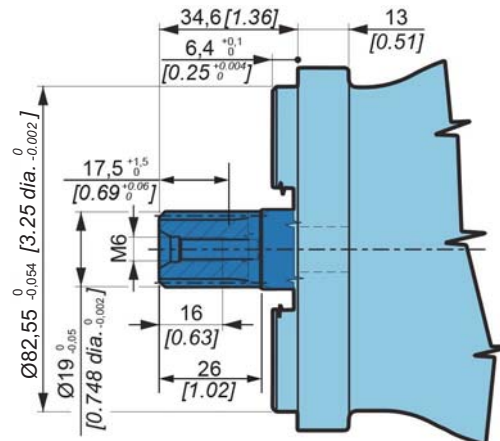

Splined info

| | |
|-----------------|------------------|
| Standard | ANSI B92.1a-1996 |
| Pitch | 16/32" D.P. |
| Number of teeth | 11 |
| Pressure angle | 30° |
| Tolerance class | 5 |

Motor M0

Motor M1

Motor M2

Motor M3

Operating parameters

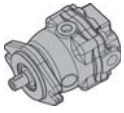

Mounting flanges and shaft



S3 Splined shaft

Max. torque: 220 Nm [1947 in.lbf]

| Splined info | |
|-----------------|------------------|
| Standard | ANSI B92.1a-1996 |
| Pitch | 16/32" D.P. |
| Number of teeth | 13 |
| Pressure angle | 30° |
| Tolerance class | 5 |

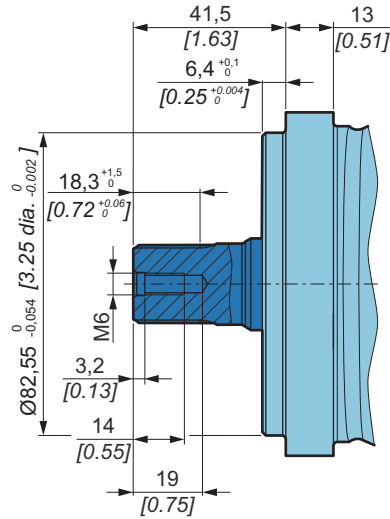



Connections



02 Side connection

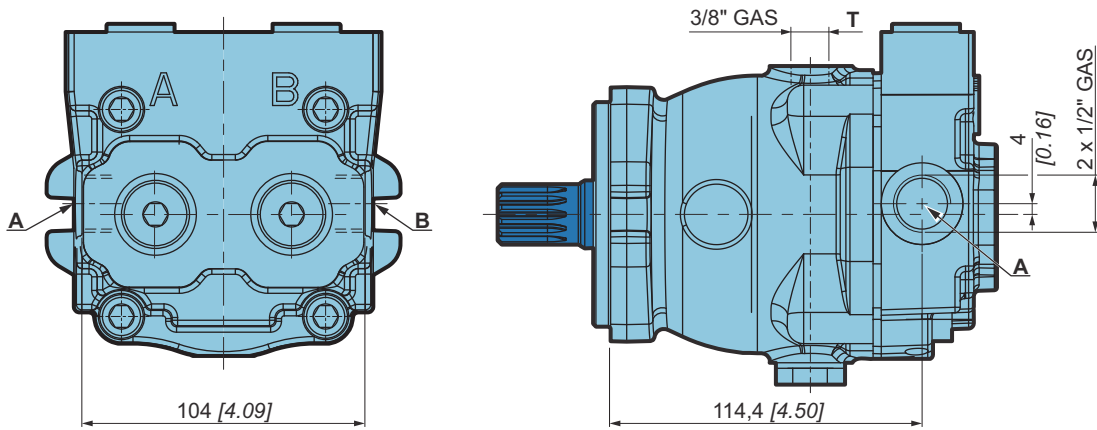

03 Twin port

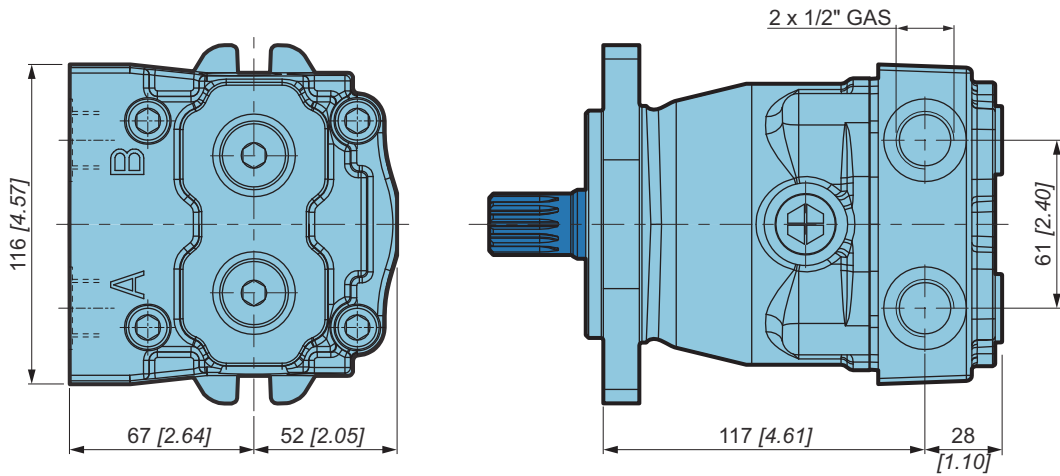

04 Rear connection

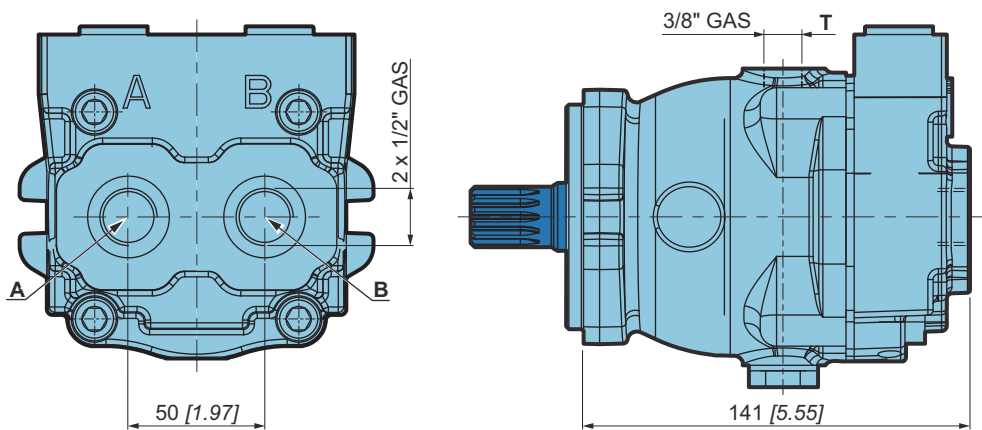

Motor M0

Motor M1

Motor M2

Motor M3

Operating parameters

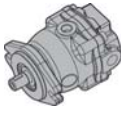

Connections



05 Side and rear connection

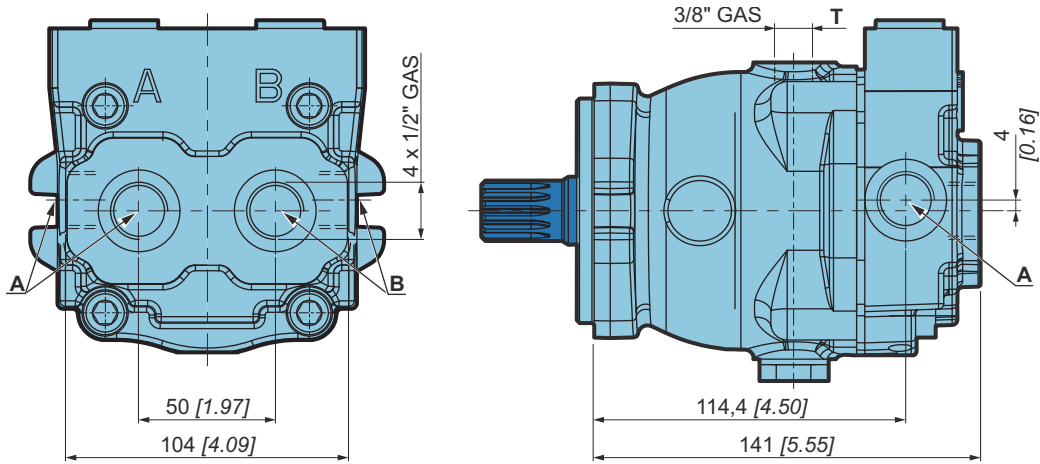



OPTIONS

Roller Bearing

| | | | | |
|------------|--------------------------|--------------------------|--------------------------|-----------|
| | 1 | 2 | 3 | 4 |
| M 1 | <input type="checkbox"/> | <input type="checkbox"/> | <input type="checkbox"/> | CR |

It is an optional high capacity bearing.

Depending on the characteristics of shaft load, the duty cycle of the application and the expected life time of your application, Roller bearing might be needed.

Consult your Poclairn Hydraulics Application Engineer.

Customized identification plate

| | | | | |
|------------|--------------------------|--------------------------|--------------------------|-----------|
| | 1 | 2 | 3 | 4 |
| M 1 | <input type="checkbox"/> | <input type="checkbox"/> | <input type="checkbox"/> | DP |

It is possible to provide our products with dedicated plate (your part number engraved on the plate) when requested.



This option is available only for minimum volume of 50 pieces.



Consult your Poclairn Hydraulics application engineer for other possibilities.

Fluorinated elastomer seals

| | | | | |
|------------|--------------------------|--------------------------|--------------------------|-----------|
| | 1 | 2 | 3 | 4 |
| M 1 | <input type="checkbox"/> | <input type="checkbox"/> | <input type="checkbox"/> | EV |

Standard NBR sealing are designed to resist temperatures up to 90°C [194° F] and HV type oils.

If your application is outside these limits, fluorinated elastomer seals might be recommended.

Consult your Poclairn Hydraulics Application Engineer.

Motor M0

Motor M1

Motor M2

Motor M3

Operating parameters



Flange port

The A and B ports are SAE flange 6000.



03 Flange ports for Twin port connection

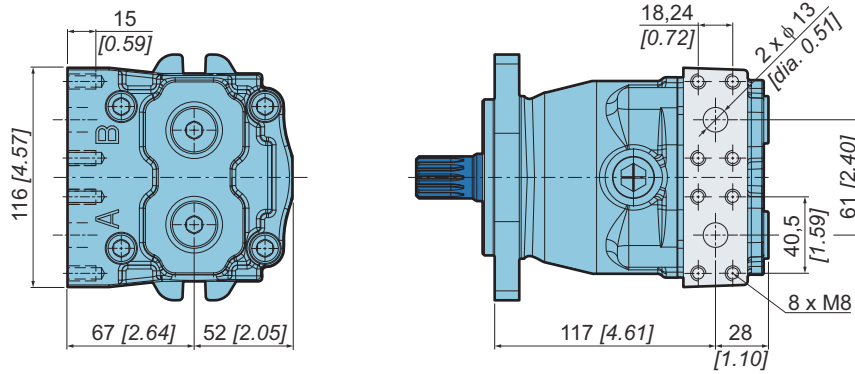

04 Flange ports for rear connection

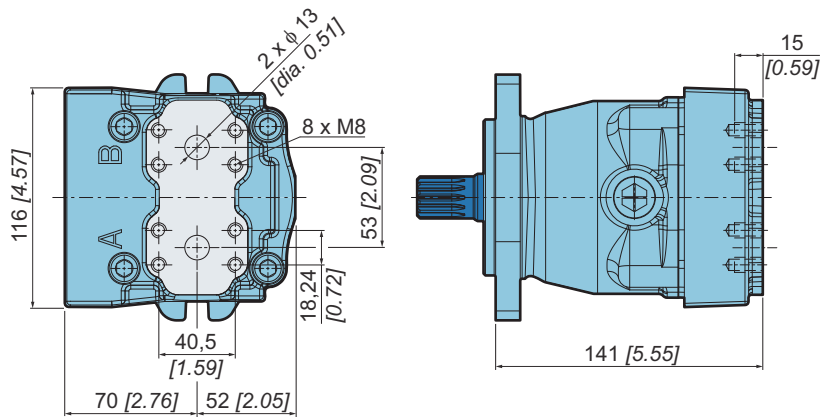

UNF Thread ports



The power supply ports A, B and drain port T are also available with UNF threads.

| Port | Function | ISO 11926-1 (option FU) |
|------|--------------|-------------------------|
| A; B | Power supply | 3/4-16 UNF-SAE |
| T | Drain | 9/16-18 UNF-SAE |



Relief valve on "A"



A relief valve is available for A side.

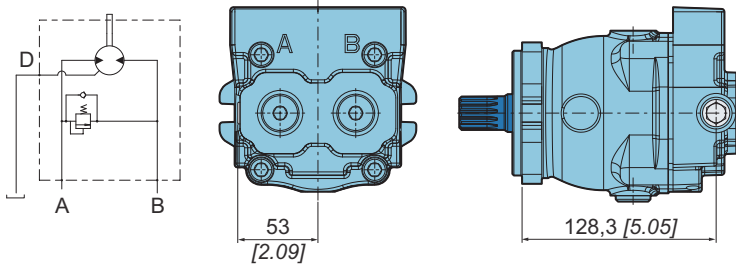

5

| High pressure relief valve setting | |
|------------------------------------|----|
| Max. system pressure (bar [PSI]) | |
| 150 [2175] | 15 |
| 200 [2900] | 20 |
| 250 [3625] | 25 |
| 300 [4351] | 30 |

Motor M0

Relief valve on "B"



A relief valve is available for B side.

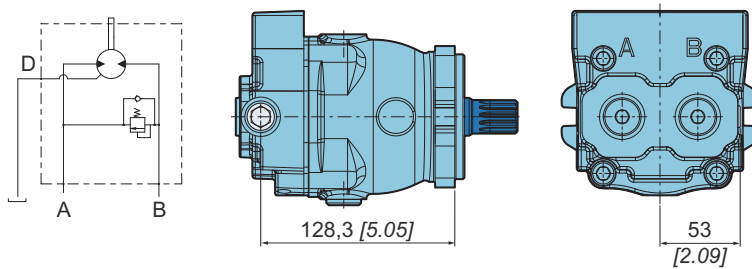

5

| High pressure relief valve setting | |
|------------------------------------|----|
| Max. system pressure (bar [PSI]) | |
| 150 [2175] | 15 |
| 200 [2900] | 20 |
| 250 [3625] | 25 |
| 300 [4351] | 30 |

Motor M1

Motor M2

Relief valve on "A+B"



A relief valve is available for A and B side.

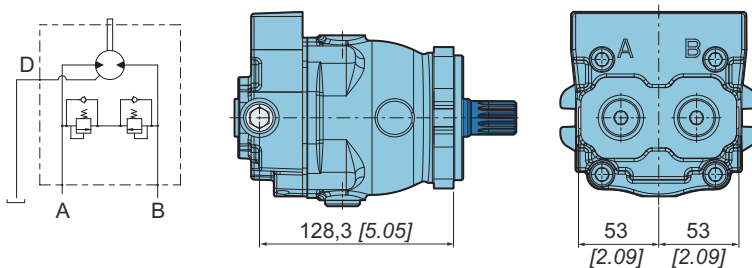

5

| High pressure relief valve setting | |
|------------------------------------|----|
| Max. system pressure (bar [PSI]) | |
| 150 [2175] | 15 |
| 200 [2900] | 20 |
| 250 [3625] | 25 |
| 300 [4351] | 30 |

Motor M3

Operating parameters

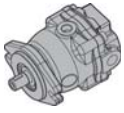

Finishing coat



The motors can be delivered with finishing coat when requested. Standard paint is RAL 9005 (black color).



Consult your Poclain Hydraulics application engineer for other colors of topcoat.

Anticavitation valve on "A"



A check valve with anticavitation function is available for A side.

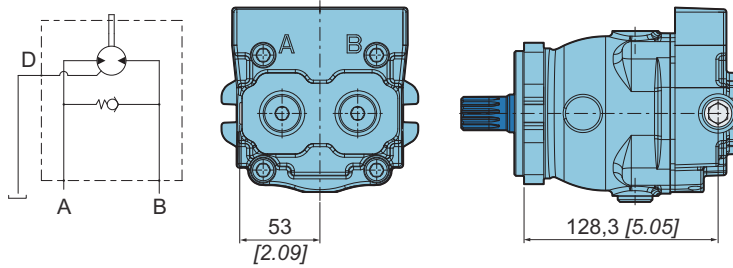

Anticavitation valve on "B"



A check valve with anticavitation function is available for B side.

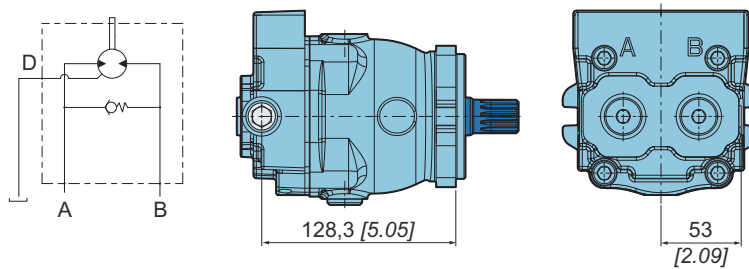



Anticavitation valve on "A+B"



A check valve with anticavitation function is available for A and B side.

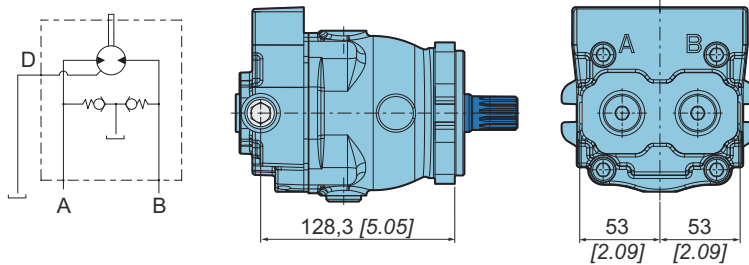

Rear drain port



The drain connection is available in the rear side of the motor.

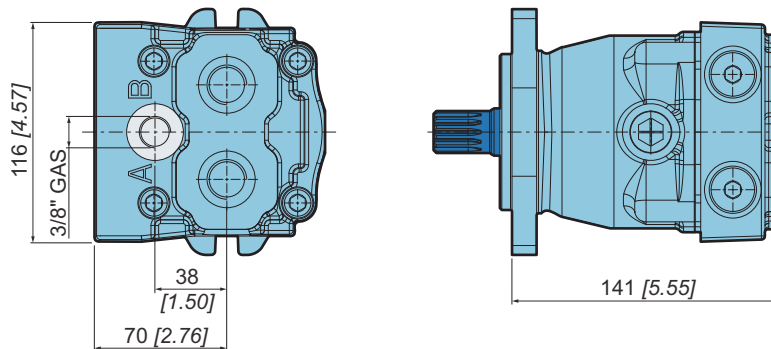

Flushing valve



An exchange valve is available for M1 motor. The valve is integrated in the motor cover and permits to control the temperature in the circuit by a flow that is directed from the low pressure side to the motor housing.

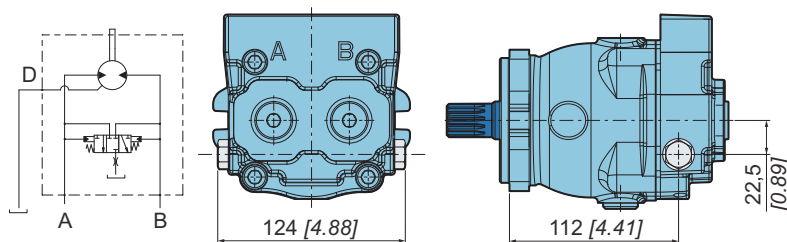

Motor M0

Motor M1

Motor M2

Motor M3

Operating parameters





MOTOR M2

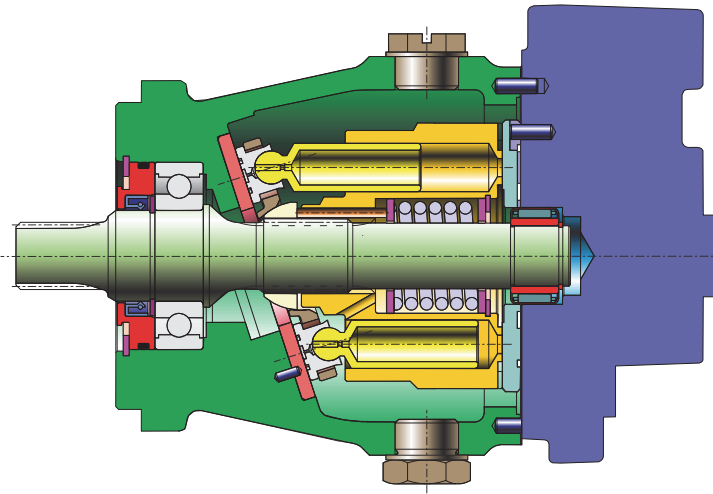

Motor M0
Motor M1
Motor M2
Motor M3
Operating parameters

MODEL CODE



1

| Displacement cm ³ /rev [in ³ /rev] | |
|--|----|
| 21,05 [1.28] | 21 |
| 24,41 [1.49] | 24 |
| 28,34 [1.73] | 28 |
| 34,36 [2.10] | 34 |
| 41,11 [2.51] | 40 |
| 45,34 [2.77] | 45 |
| 49,06 [2.99] | 50 |

2

| Shaft | |
|------------------------------------|----|
| Key shaft (D=22,22 mm [0.87 inch]) | C3 |
| Key shaft (D=25 mm [0.98 inch]) | D6 |
| Splined shaft (Z=13; 16/32 D.P.) | S3 |
| Splined shaft (Z=15; 16/32 D.P.) | S4 |

3

| Connections | |
|---------------|----|
| Side | 02 |
| Twin port | 03 |
| Rear | 04 |
| Side and rear | 05 |

4

| Options | |
|--|----|
| Without options | 00 |
| Roller bearings | CR |
| Customized identification plate | DP |
| Fluorinated elastomer seals | EV |
| Flange port | FS |
| UNF Thread ports | FU |
| Relief valve on "A" | MA |
| Relief valve on "B" | MB |
| Relief valve on "A+B" | MM |
| Finishing coat | PA |
| Anticavitation valve on "A" | RA |
| Anticavitation valve on "B" | RB |
| Rear drain port | RD |
| T4 speed sensor (without rotation direction) | SS |
| Flushing valve | VS |

In case of request for a combination of several options, please contact your Poclain Hydraulics application engineer for further information.

5*

| High pressure relief valve setting Max. system pressure (bar [PSI]) | |
|--|----|
| 150 [2175] | 15 |
| 200 [2900] | 20 |
| 250 [3625] | 25 |
| 300 [4351] | 30 |

* Motors with option MA, MB, MM.



Mounting flanges and shaft



C3 Key shaft

Max. torque: 220 Nm [1947 in.lbf]

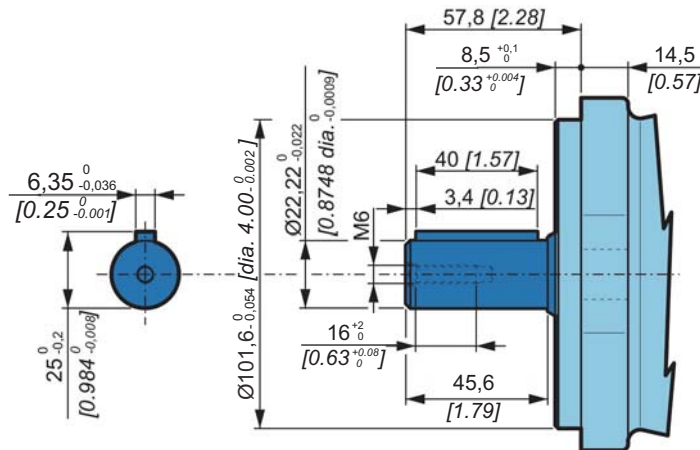

Motor M0

Motor M1

D6 Key shaft

Max. torque: 280 Nm [2478 in.lbf]

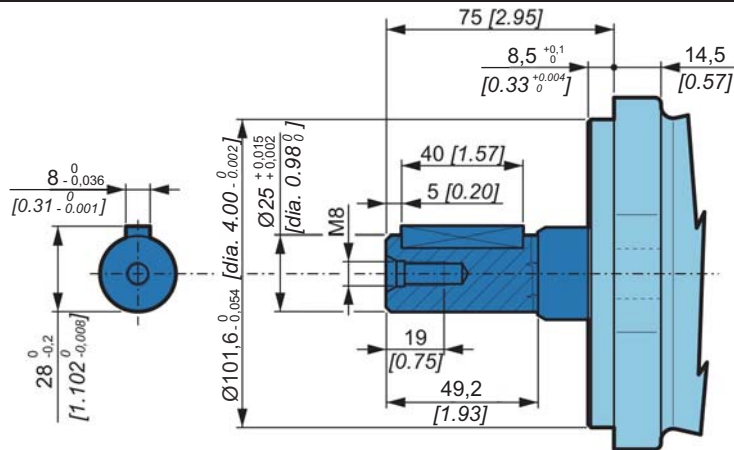

Motor M2

Motor M3

Operating parameters



Mounting flanges and shafts



S3 Splined shaft

Max. torque: 220 Nm [1947 in.lbf]

| Splined info | |
|-----------------|------------------|
| Standard | ANSI B92.1a-1996 |
| Pitch | 16/32" D.P. |
| Number of teeth | 13 |
| Pressure angle | 30° |
| Tolerance class | 5 |

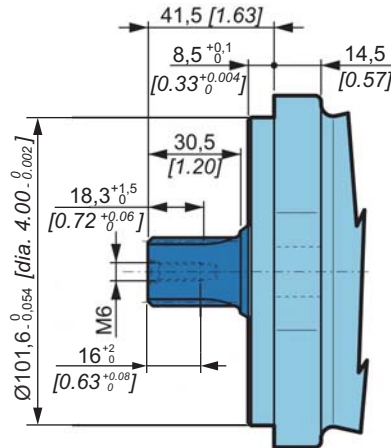

S4 Splined shaft

Max. torque: 360 Nm [3186 in.lbf]

| Splined info | |
|-----------------|------------------|
| Standard | ANSI B92.1a-1996 |
| Pitch | 16/32" D.P. |
| Number of teeth | 15 |
| Pressure angle | 30° |
| Tolerance class | 5 |

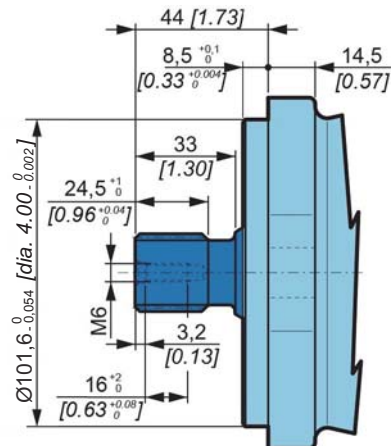



Connections



02 Side connection

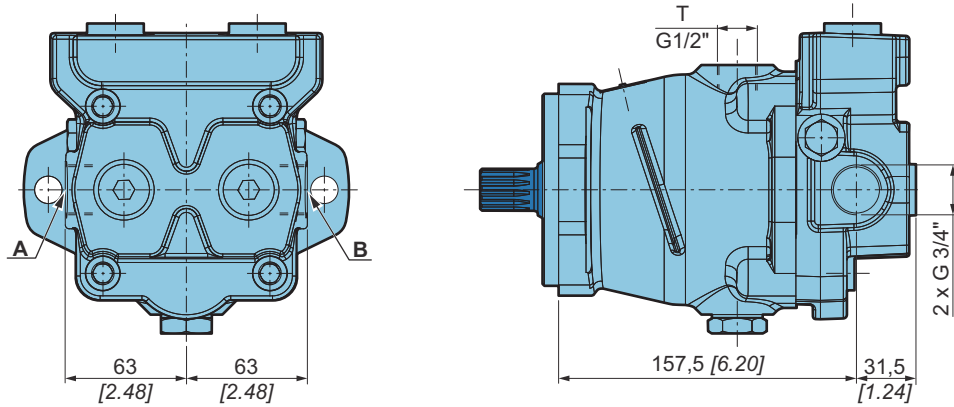

03 Twin port - same side

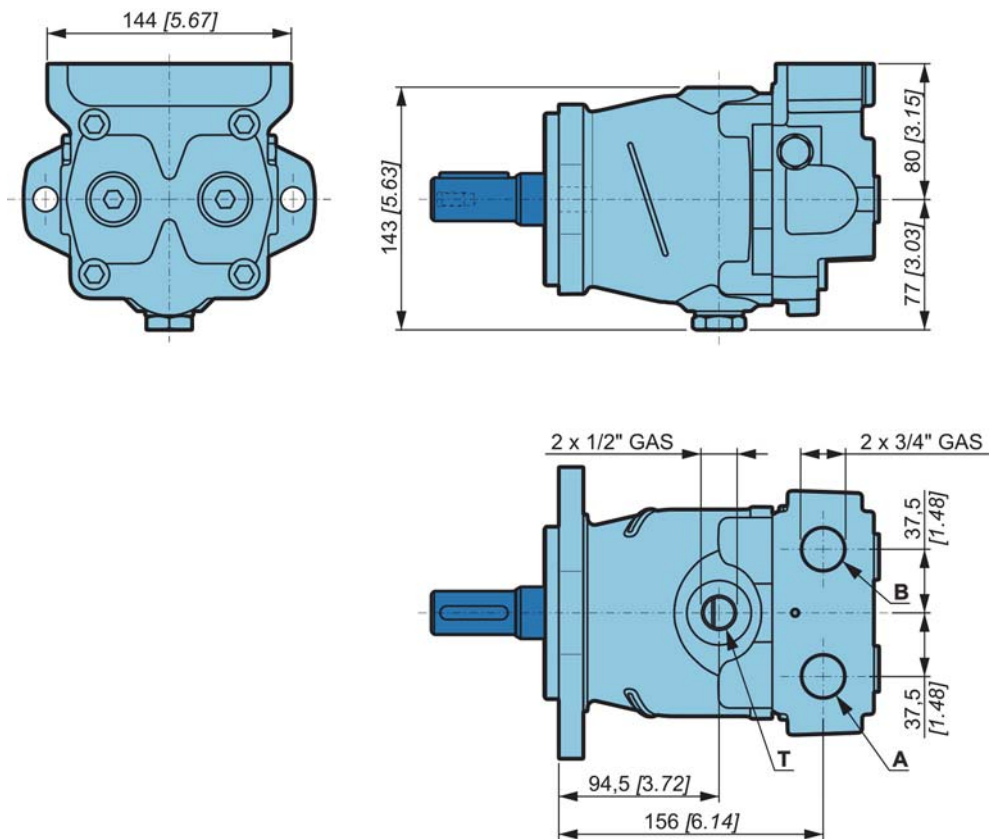

Motor M0

Motor M1

Motor M2

Motor M3

Operating parameters



Connections



04 Rear connection

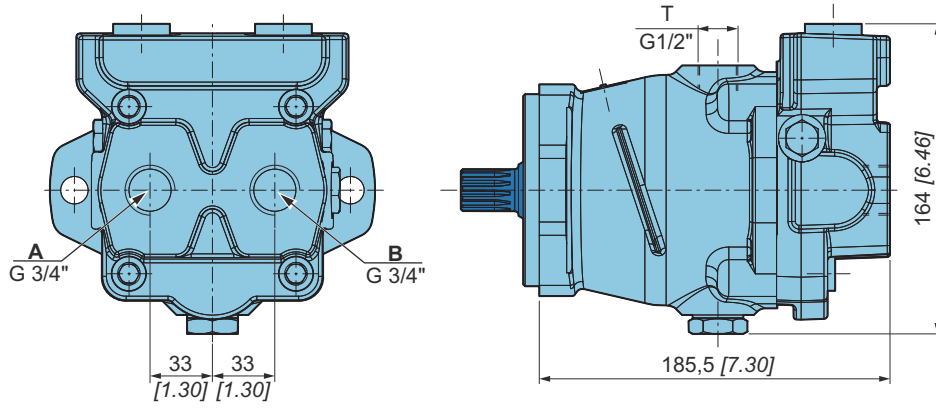

05 Side and rear connection

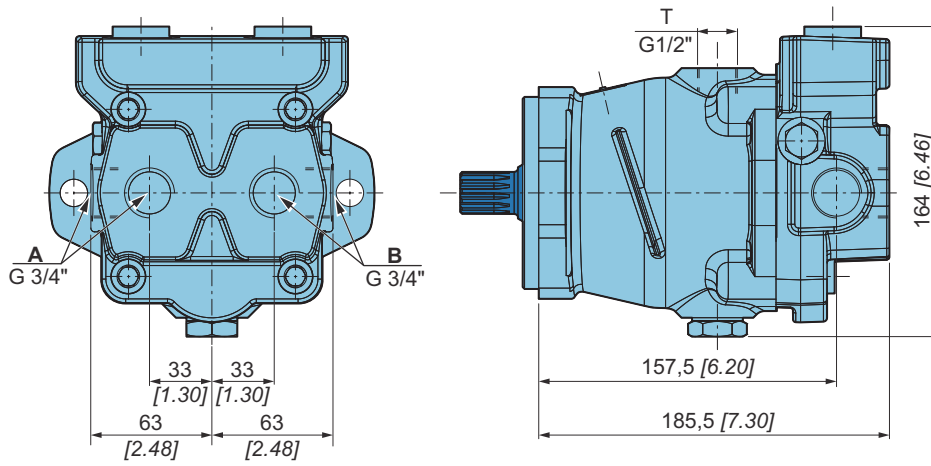



OPTIONS

Roller Bearing



It is an optional high capacity bearing.

Depending on the characteristics of shaft load, the duty cycle of the application and the expected life time of your application, Roller bearing might be needed.

Consult your Poclain Hydraulics Application Engineer.

Customized identification plate



It is possible to provide our products with dedicated plate (your part number engraved on the plate) when requested.



This option is available only for minimum volume of 50 pieces.



Consult your Poclain Hydraulics application engineer for other possibilities.

Fluorinated elastomer seals



Standard NBR sealing are designed to resist temperatures up to 90°C [194° F] and HV type oils.

If your application is outside these limits, fluorinated elastomer seals might be recommended.

Consult your Poclain Hydraulics Application Engineer.

Motor M0

Motor M1

Motor M2

Motor M3

Operating parameters



Flange port

The A and B ports are SAE flange 6000.



03 Flange ports for Twin port connection

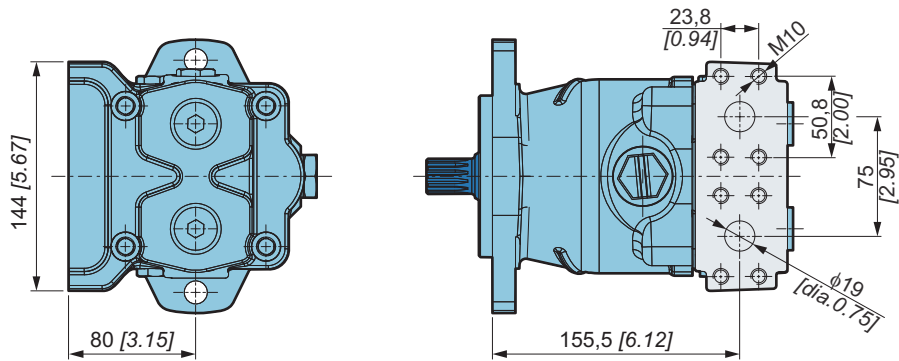

04 Flange ports for rear connection

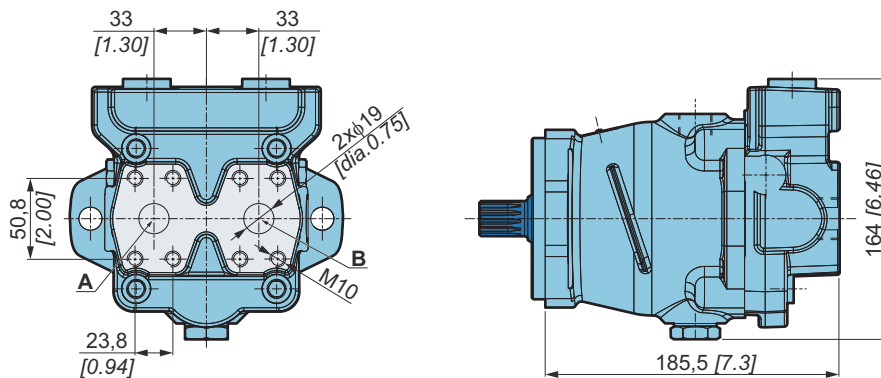

UNF Thread ports



The power supply ports A, B and drain port T are also available with UNF threads.

| Port | Function | ISO 11926-1 (option FU) |
|------|--------------|-------------------------|
| A; B | Power supply | 1-1/16-12 UNF |
| T | Drain | 3/4-16 UNF |



Relief valve on "A"



A relief valve is available for A side.

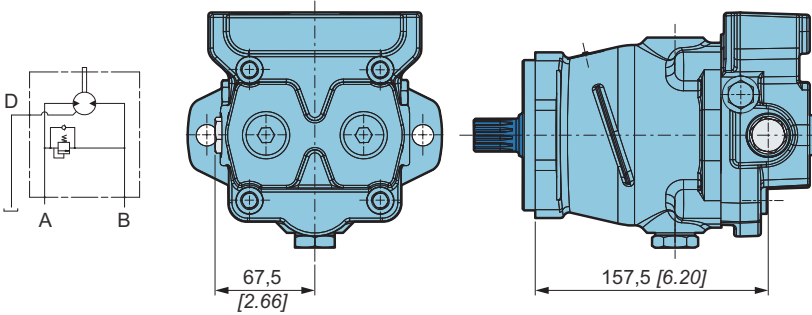

| | |
|---|----|
| 5 | |
| High pressure relief valve setting | |
| Max. system pressure (bar [PSI]) | |
| 150 [2175] | 15 |
| 200 [2900] | 20 |
| 250 [3625] | 25 |
| 300 [4351] | 30 |

Motor M0

Motor M1

Relief valve on "B"



A relief valve is available for B side.

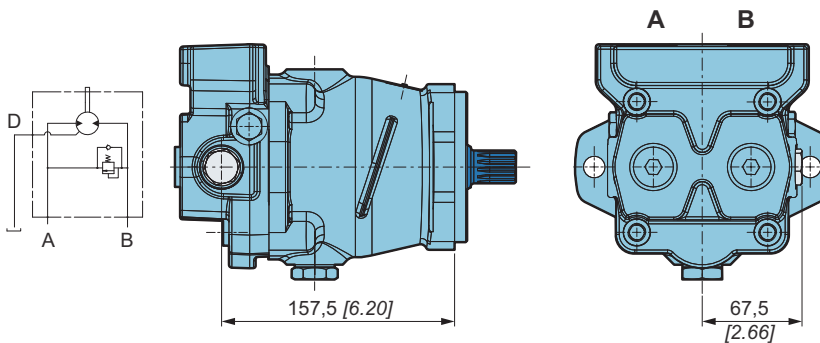

| | |
|---|----|
| 5 | |
| High pressure relief valve setting | |
| Max. system pressure (bar [PSI]) | |
| 150 [2175] | 15 |
| 200 [2900] | 20 |
| 250 [3625] | 25 |
| 300 [4351] | 30 |

Motor M2

Relief valve on "A+B"



A relief valve is available for A and B side.

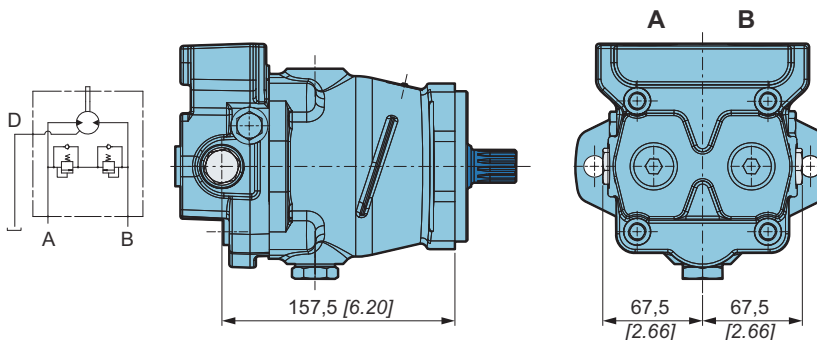

| | |
|---|----|
| 5 | |
| High pressure relief valve setting | |
| Max. system pressure (bar [PSI]) | |
| 150 [2175] | 15 |
| 200 [2900] | 20 |
| 250 [3625] | 25 |
| 300 [4351] | 30 |

Motor M3

Operating parameters



Finishing coat



The motors can be delivered with finishing coat when requested. Standard paint is RAL 9005 (black color).



Consult your Poclain Hydraulics application engineer for other colors of topcoat.

Anticavitation valve on "A"



A check valve with anticavitation function is available for A side.

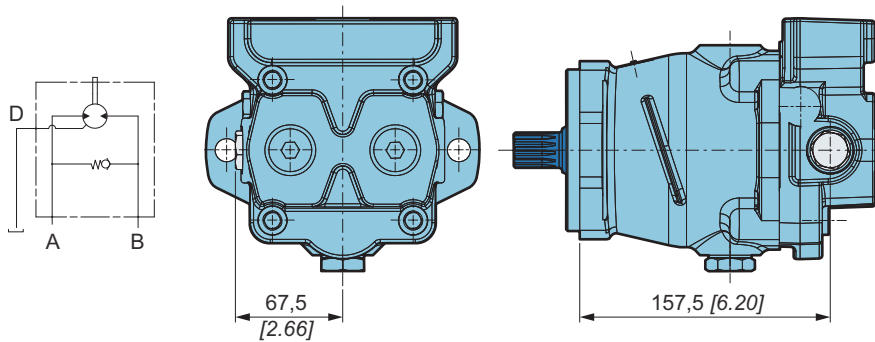

Anticavitation valve on "B"



A check valve with anticavitation function is available for B side.

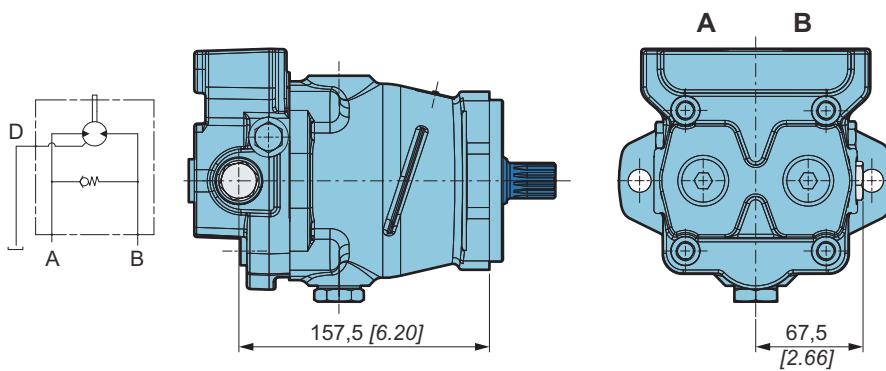



Rear drain port



The drain connection is available in the rear side of the motor.

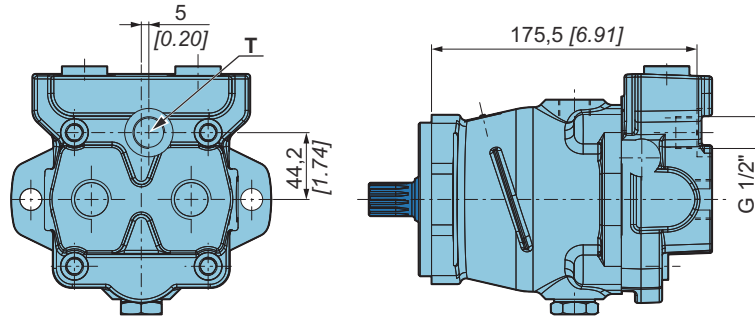

Speed sensor



A speed sensor can be installed on M2 motor.

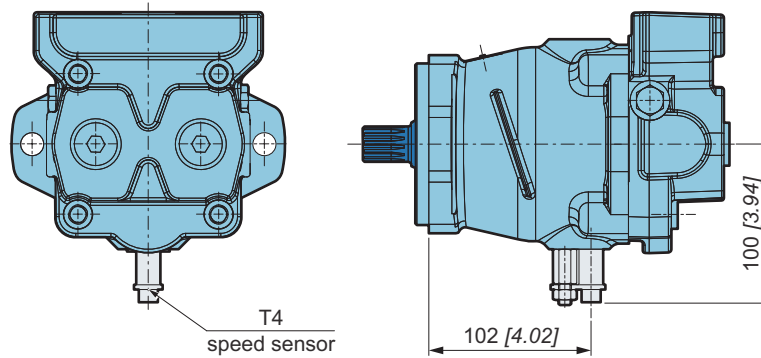

Look at the "Mobile Electronic" N° A01889D technical catalogue for the sensor specifications and its connection.



Speed sensor sends a signal of 9 pulses per revolution.

Motor M0

Motor M1

Motor M2

Motor M3

Operating parameters



Flushing valve



An exchange valve is available for M2 motor. The valve is integrated in the motor cover and permits to control the temperature in the circuit by a flow that is directed from the low pressure side to the motor housing.

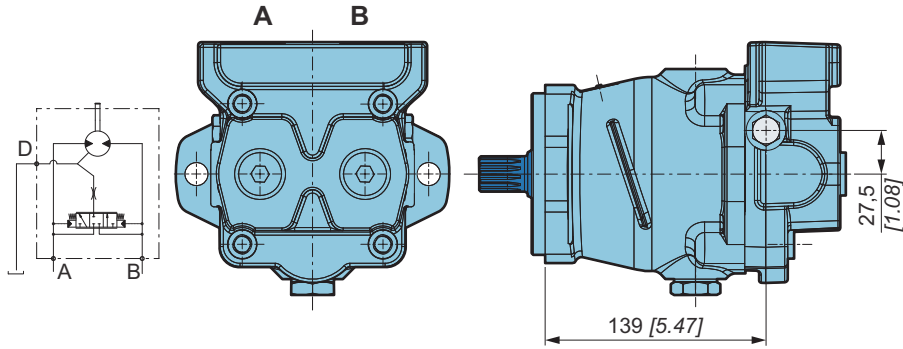



MOTOR M3

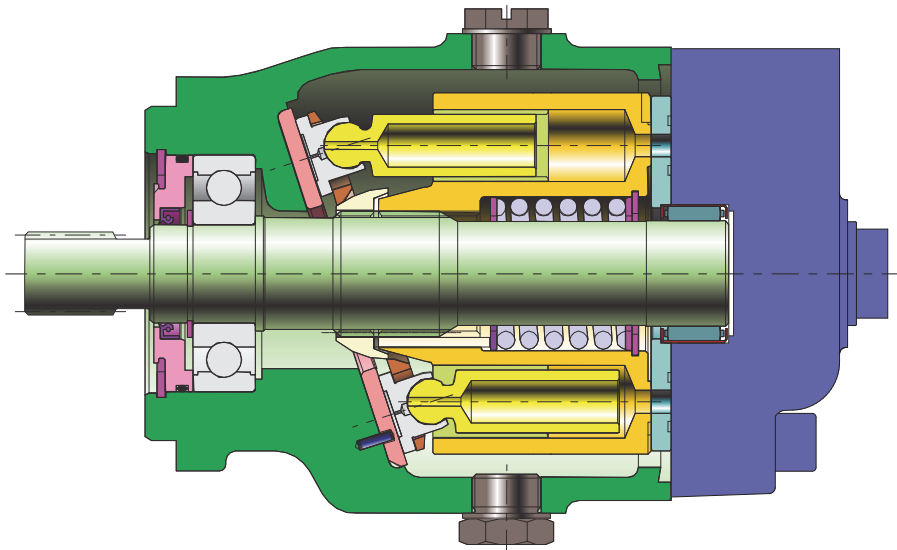

Motor M0
Motor M1
Motor M2
Motor M3
Operating parameters

MODEL CODE



1

| Displacement cm^3/rev [in^3/rev] | |
|--|----|
| 49,57 [3.02] | 50 |
| 57,01 [3.48] | 55 |
| 60,79 [3.71] | 60 |
| 64,60 [3.94] | 65 |

2

| Shaft | |
|----------------------------------|----|
| Key shaft (D=25 mm [0.98 inch]) | D6 |
| Splined shaft (Z=13; 16/32 D.P.) | S3 |
| Splined shaft (Z=15; 16/32 D.P.) | S4 |

3

| Connections | |
|---------------|----|
| Side | 02 |
| Twin port | 03 |
| Rear | 04 |
| Side and rear | 05 |

4

| Options | |
|--|----|
| Without options | 00 |
| Customized identification plate | DP |
| Fluorinated elastomer seals | EV |
| Flange port | FS |
| UNF Thread ports | FU |
| Relief valve on "A" | MA |
| Relief valve on "B" | MB |
| Relief valve on "A+B" | MM |
| Finishing coat | PA |
| Anticavitation valve on "A" | RA |
| Anticavitation valve on "B" | RB |
| Anticavitation valve on "A+B" | RR |
| Rear drain port | RD |
| T4 speed sensor (without rotation direction) | SS |
| Flushing valve | VS |



In case of request for a combination of several options, please contact your Poclain Hydraulics application engineer for further information.

5*

| High pressure relief valve setting Max. system pressure (bar [PSI]) | |
|--|----|
| 150 [2175] | 15 |
| 200 [2900] | 20 |
| 250 [3625] | 25 |
| 300 [4351] | 30 |

* Motors with option MA, MB, MM.



CHARACTERISTICS

Features

| | | |
|----------------------------------|--|---|
| Displacement | cm ³ /rev [in ³ /rev.] | From 49,57 [3.02] to 64,60 [3.94] |
| Max. speed | rpm | 3 600 |
| Min. speed | rpm | 500 |
| Rated pressure | bar [PSI] | 250 [3625] |
| Max. pressure | bar [PSI] | 350 [5076] |
| Min. charge pressure | bar [PSI] | 5-6 [72-87] |
| Mounting flange and shaft | | SAE-B |
| Weight | kg [lb] | 15 [33.07] |
| Rotation | | Clockwise (B to A) or Counterclockwise (A to B) |

Motor Performance

Power of the motor given at rated pressure and max. speed

| | | | | |
|---|--------------|---------------|---------------|---------------|
| Displacement cm ³ /rev [in ³ /rev.] | 49,57 [3.02] | 57,01 [3.48] | 60,79 [3.71] | 64,60 [3.94] |
| Power kW [hp] | 74,4 [99.77] | 85,5 [114.66] | 91,2 [122.30] | 96,9 [129.95] |

Dimensions

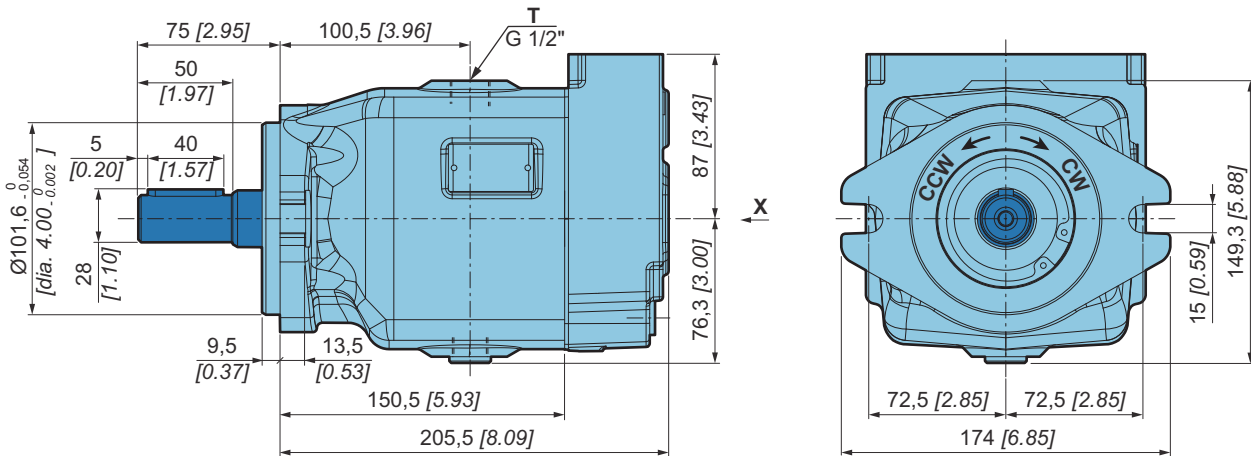

VIEW "X"

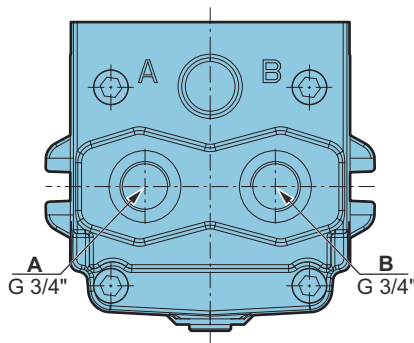

| Rotation | Flow direction |
|-------------------------|----------------|
| Clockwise (CW) | B to A |
| Counter clockwise (CCW) | A to B |

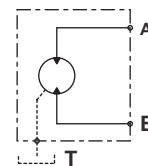



Mounting flanges and shafts



D6 Key shaft Max. torque: 280 Nm [2478 in.lbf]

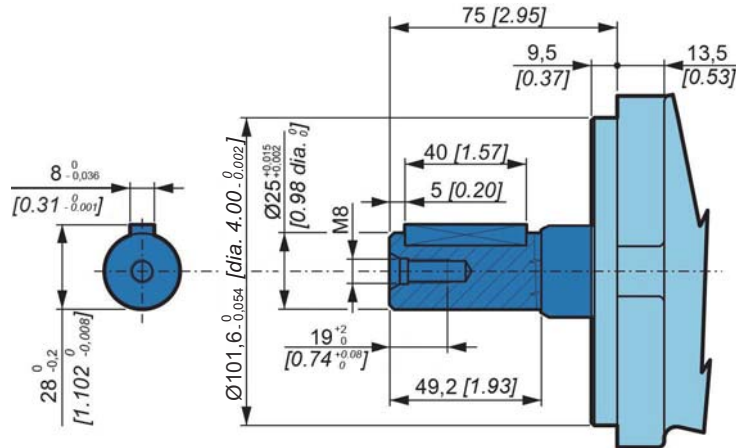

S3 Splined shaft Max. torque: 220 Nm [1947 in.lbf]

| Splined info | |
|-----------------|------------------|
| Standard | ANSI B92.1a-1996 |
| Pitch | 16/32" D.P. |
| Number of teeth | 13 |
| Pressure angle | 30° |
| Tolerance class | 5 |

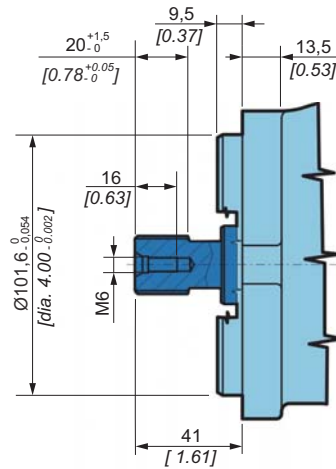

S4 Splined shaft Max. torque: 360 Nm [3186 in.lbf]

| Splined info | |
|-----------------|------------------|
| Standard | ANSI B92.1a-1996 |
| Pitch | 16/32" D.P. |
| Number of teeth | 15 |
| Pressure angle | 30° |
| Tolerance class | 5 |

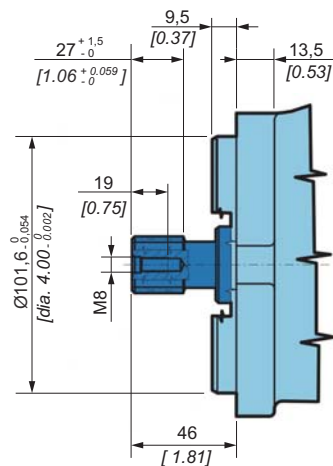

Motor M0

Motor M1

Motor M2

Motor M3

Operating parameters



Connections



02 Side connection

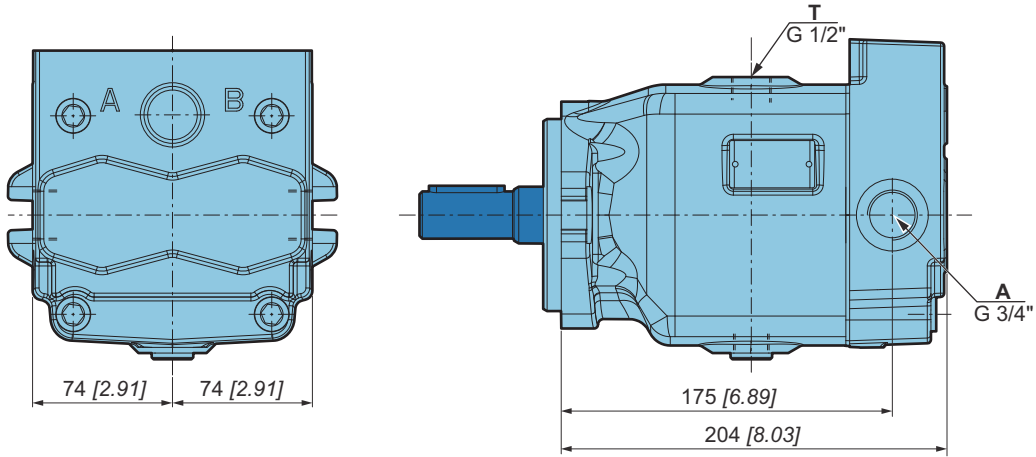

03 Twin port - same side

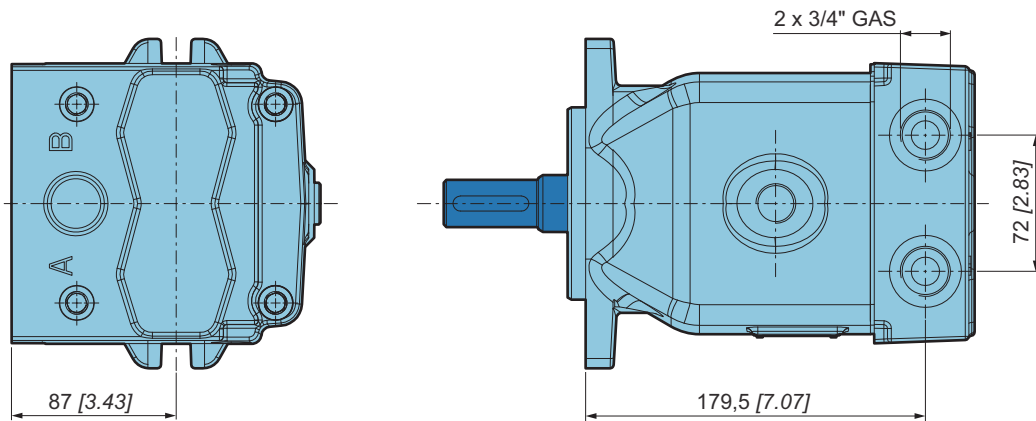

04 Rear connection

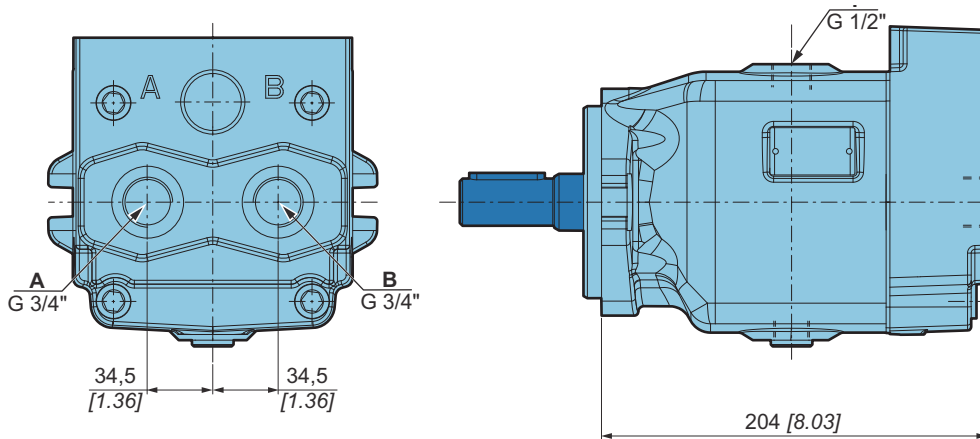



Connections



05 Side and rear connection

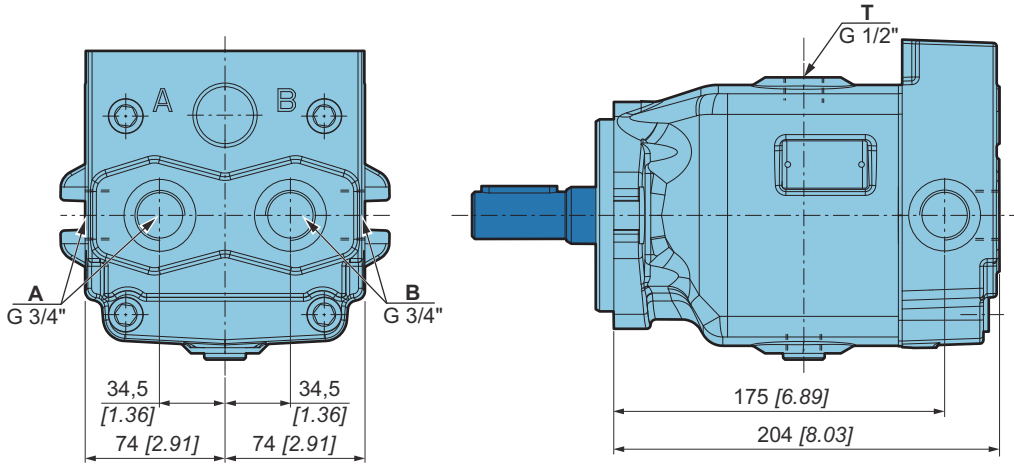

Motor M0

Motor M1

Motor M2

Motor M3

Operating parameters



OPTIONS

Customized identification plate



It is possible to provide our products with dedicated plate (your part number engraved on the plate) when requested.



This option is available only for minimum volume of 50 pieces.



Consult your Poclain Hydraulics application engineer for other possibilities.

Fluorinated elastomer seals



Standard NBR sealing are designed to resist temperatures up to 90°C [194° F] and HV type oils.

If your application is outside these limits, fluorinated elastomer seals might be recommended.

Consult your Poclain Hydraulics Application Engineer.



Flange port

The A and B ports are SAE flange 6000.



03 Flange ports for Twin port connection

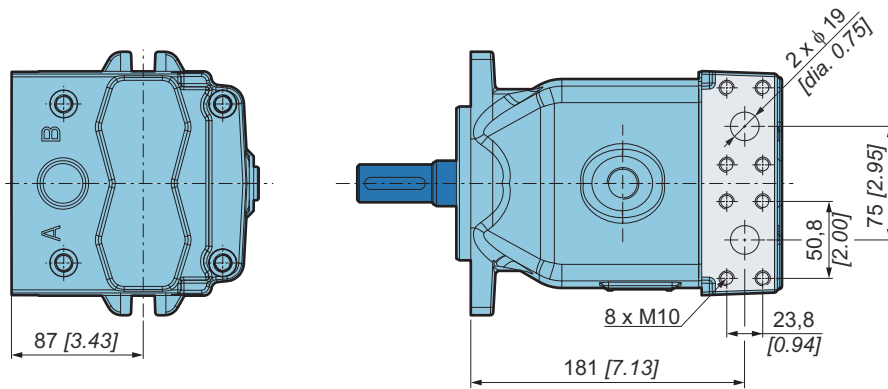

04 Flange ports for rear connection

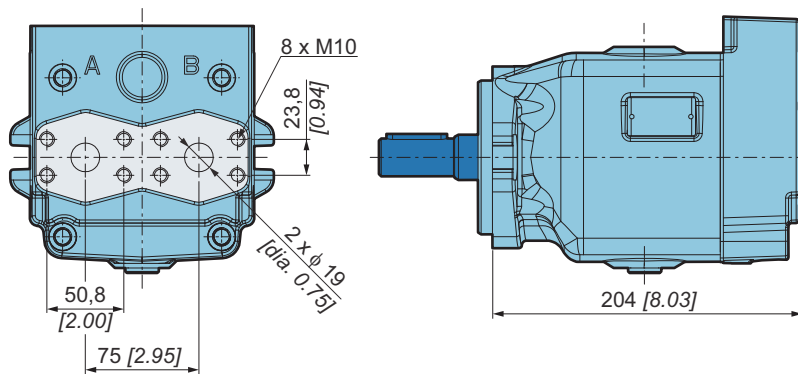

UNF Thread ports



The power supply ports A, B and drain port T are also available with UNF threads.

| Port | Function | ISO 11926-1 (option FU) |
|------|--------------|-------------------------|
| A; B | Power supply | 1-1/16-12 UNF |
| T | Drain | 3/4-16 UNF |

Motor M0

Motor M1

Motor M2

Motor M3

Operating parameters



Relief valve on "A"



A relief valve is available for A side.

5

| High pressure relief valve setting | |
|------------------------------------|----|
| Max. system pressure (bar [PSI]) | |
| 150 [2175] | 15 |
| 200 [2900] | 20 |
| 250 [3625] | 25 |
| 300 [4351] | 30 |

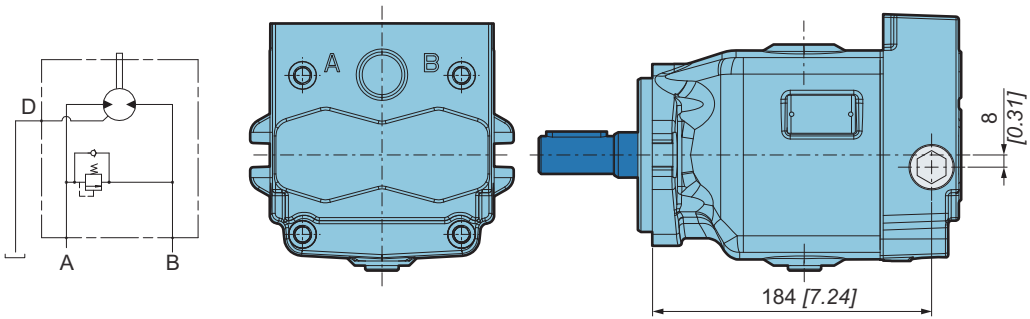

Relief valve on "B"



A relief valve is available for B side.

5

| High pressure relief valve setting | |
|------------------------------------|----|
| Max. system pressure (bar [PSI]) | |
| 150 [2175] | 15 |
| 200 [2900] | 20 |
| 250 [3625] | 25 |
| 300 [4351] | 30 |

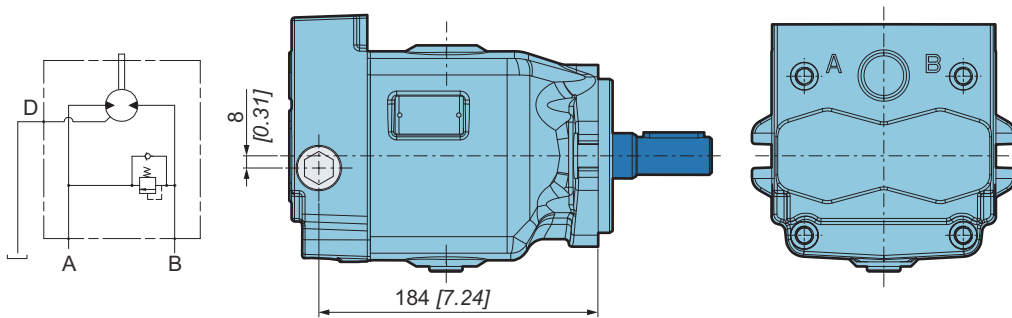



Relief valve on “A+B”



A relief valve is available for A and B side.

5

| High pressure relief valve setting | |
|------------------------------------|----|
| Max. system pressure (bar [PSI]) | |
| 150 [2175] | 15 |
| 200 [2900] | 20 |
| 250 [3625] | 25 |
| 300 [4351] | 30 |

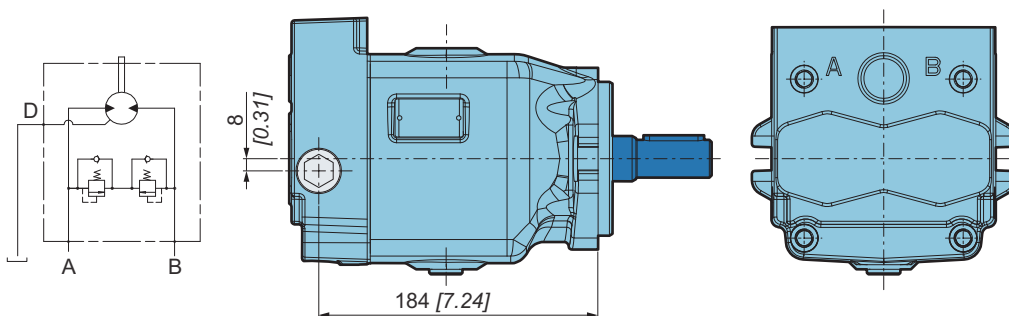

Finishing coat



The motors can be delivered with finishing coat when requested. Standard paint is RAL 9005 (black color).



Consult your Poclain Hydraulics application engineer for other colors of topcoat.

Anticavitation valve on “A”



A check valve with anticavitation function is available for A side.

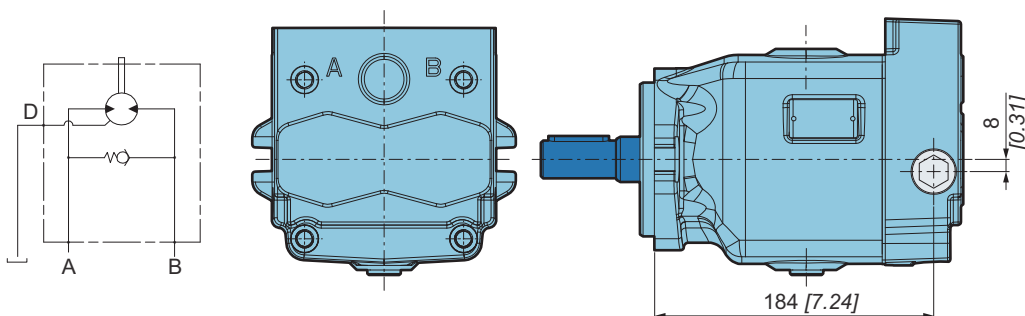

Motor M0

Motor M1

Motor M2

Motor M3

Operating parameters



Anticavitation valve on "B"



A check valve with anticavitation function is available for B side.

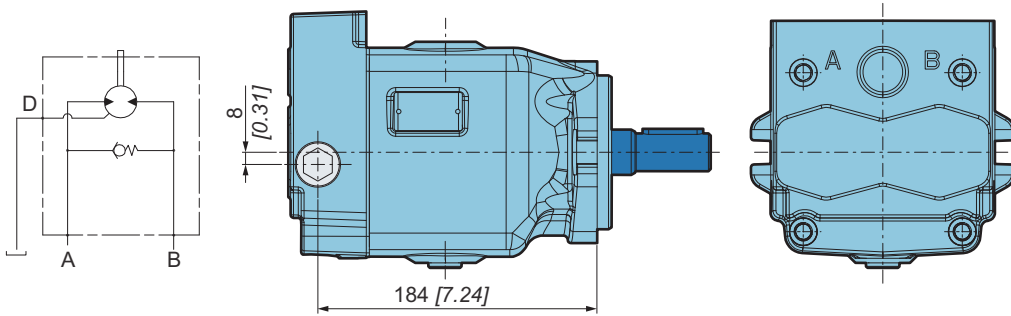

Anticavitation valve on "A+B"



A check valve with anticavitation function is available for A and B side.

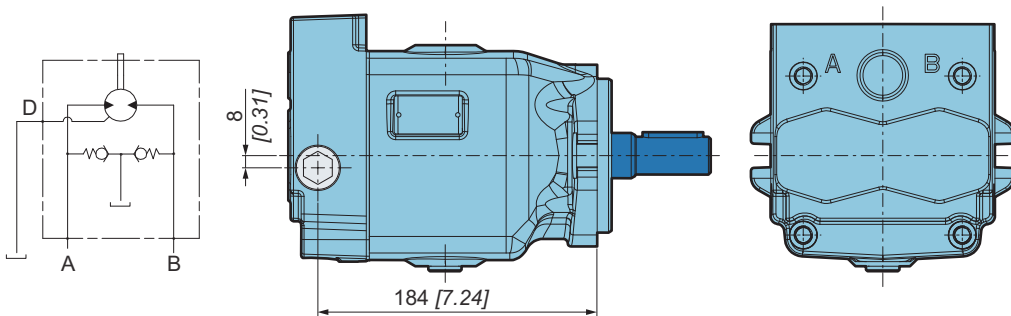

Rear drain port



The drain connection is available in the rear side of the motor.

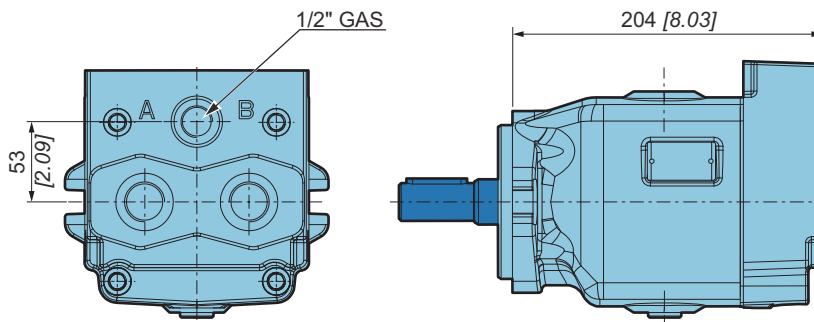



Installed speed sensor



A speed sensor can be installed on M3 motor.

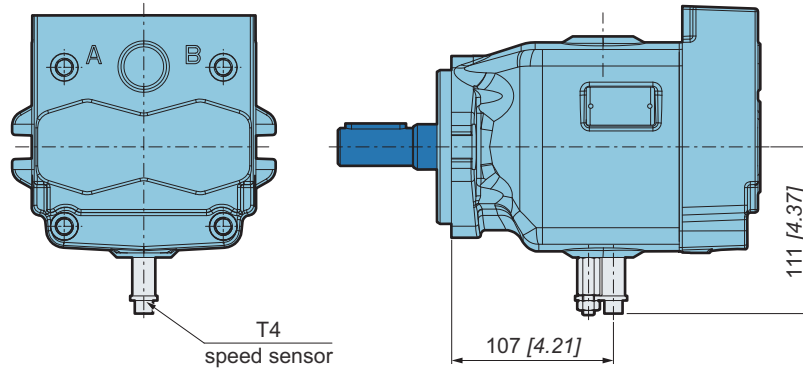

Look at the "Mobile Electronic" N° A01889D technical catalogue for the sensor specifications and its connection.



Speed sensor sends a signal of 9 pulses per revolution.

Flushing valve



An exchange valve is available for M3 motor. The valve is integrated in the motor cover and permits to control the temperature in the circuit by a flow that is directed from the low pressure side to the motor housing.

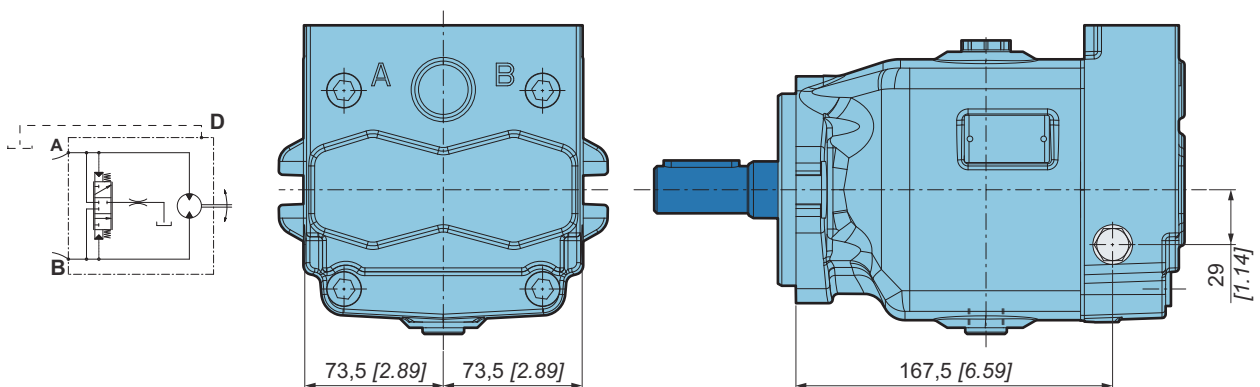

Motor M0

Motor M1

Motor M2

Motor M3

Operating parameters



OPERATING PARAMETERS

Poclair Hydraulics recommendations for fluid



Poclair hydraulics recommends the use of hydraulic fluids defined by the ISO 15380 and ISO 6743-4 standards.

For temperate climates, the following types are recommended.

- HM 46 or HM 68 for fixed installations.
- HV 46 or HV 68 for mobile installations.
- HEES 46 for mobile installations.

These specifications correspond to category 91H of the CETOP standard, parts 1, 2 and 3 of the DIN 51524 standard, and grades VG32, VG 46 and VG68 of the ISO 6743-4 standards.



It is also possible to use ATF, HD, HFB, HFC or HFD type hydraulic fluid upon Poclair Hydraulics specific approval of the components' operating conditions.

Standardized designations for the fluids

- **HM** : Mineral fluids having specific antioxidant, anticorrosion and antiwear properties (HLP equivalent to DIN 51524 parts 1 and 2).
- **HV** : HM mineral fluids providing improved temperature and viscosity properties (DIN 51524 part 3).
- **HEES** : Biodegradable fluids based on organic esters.



It is also possible to use a fluid that meets the biodegradability criteria and is compatible in the event of accidental food contact. The BIOHYDRAN FG 46 fluid designed by the company Total has undergone testing of its properties and performance on our test benches. Since this type of fluid has not yet been categorized, it is the responsibility of machine manufacturers to validate its compatibility with all of the components used in order to guarantee that the intended functions will be fulfilled and this for the desired life time of all equipment items.



For biodegradable fluids, consult your Poclair Hydraulics' application engineer



During operation, the temperature of the oil must be between 0°C [32°F] and 80°C [176°F]; the minimum and maximum temperatures may be exceeded momentarily by ± 20°C [± 68°F] for a duration of less than 30 minutes. For all applications outside these limits, please consult with your Poclair Hydraulics' application engineer.

Fluid and filtration

The contaminating particles suspended in the hydraulic fluid cause the hydraulic mechanisms moving part wear. On hydraulic pumps, these parts operate with very small dimensional tolerances. In order to reach the part life, it is recommended to use a filter that maintains the hydraulic fluid contamination class at a max. of:

- 9 according to NAS 1638
- 20/18/15 according to ISO 4406:1999

According to the type of application decided for the pump, it is necessary to use filtration elements with a filtration ratio of:

$$\beta_{20 \text{ to } 30} \geq 100$$

Making sure that this ratio does not worsen together with the increasing of the filter cartridge differential pressure.

If these values cannot be observed, the component life will consequently be reduced and it is recommended to contact the Poclair Hydraulics Customer Service.

Filters on charge circuit

Filters on the charge circuit (F0-F2) are designed without by-pass. The max. pressure drop on the filtration part must not exceed 2 bar [29 PSI] (3 bar [43.5 PSI] in case of cold starting) at pump full rating. To monitor the pressure drop, it is recommended to use the clogging indicator on the filtration element (F2 option). Contact your Poclair Hydraulics Application engineer, each time the pump is not charged by its internal charge pump.

Filters on charge circuit are mounted on the pump special support.

Filters assembling

The suction filter is mounted on the suction line. Check that the pressure before the charge pump is 0.8 bar abs. [11.6 PSI abs.], measured on the pump suction port (0.5 bar [7.2 PSI] for cold starting).



Viscosity range

For both max. efficiency and life of the unit, the operative viscosity should be chosen within the optimum range of:
 $\sqrt{\text{opt}}$ = optimum operating viscosity from 16 to 36 mm²/s [from 74.1 to 166.8 SUS] referred to the closed loop temperature.

Working conditions: the following limits of viscosity apply

$\sqrt{\text{min}}$ = 5 mm²/s [23 SUS] short-duration at a max. permissible leakage oil temperature of 90° C [194°F]

$\sqrt{\text{max}}$ = 1000 mm²/s [4 634 SUS] short-duration, on cold start.

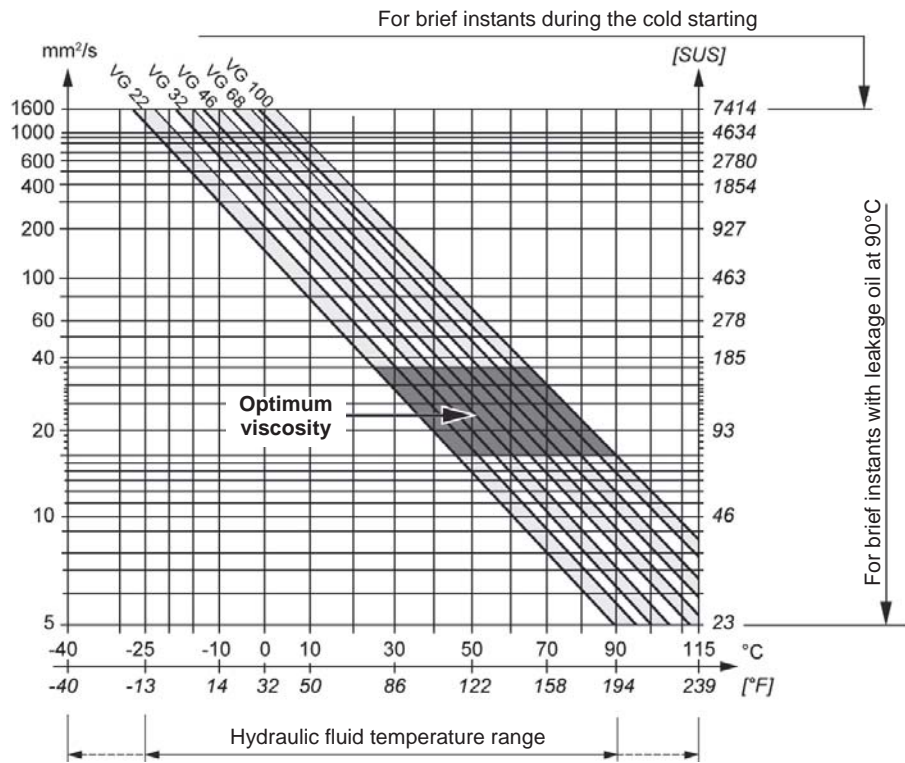

Ensure fluid temperature and viscosity limits are concurrently satisfied.

Motor M0

Motor M1

Motor M2

Motor M3

Operating parameters



Poclain Hydraulics reserves the right to make any modifications it deems necessary to the products described in this document without prior notification. The information contained in this document must be confirmed by Poclain Hydraulics before any order is submitted.

Illustrations are not binding.

The Poclain Hydraulics brand is the property of Poclain Hydraulics S.A.

 24/03/2017

 Not available

 A35770F

 Not available

 Not available

 Not available

 B33976E

 Not available

 Not available

